

FUTURE

WORKPLACE

Your Furniture & Flooring Partner

COMMERCIAL | HEALTHCARE | HOSPITALITY | EDUCATION



# Flooring Catalogue



## Introduction



**"Forward"** - Symbolizing innovation and evolution in workplace furniture solution.



**"Wellbeing"** - Emphasizing the focus on creating ergonomic and comfortable workspaces.



**"Precision"** - Reflecting the attention to detail and craftsmanship in your furniture designs.

## Our Commitment

- 01.** We are committed to healthy and productive work environment. We supply sustainable, recyclable and green products with the help of our manufacturers.
- 02.** We are specialized in innovative workplace design and furniture by bringing a modern touch to your office workspace.
- 03.** Committed to provide workplace furniture that delivers great value by combining modern design, high quality and exceptional service.



## OUR KEY PARTNERS



**WELSPUN**

**Mannington®**



**Lindner**

## Our Services



### Space Planning and Designing

We transform empty spaces into functional, human-centric environments tailored to your workflow. Our space planning blends precision, creativity, and the right furniture to bring your vision to life.



### Design Specification Visualization

We translate your thoughts into joyful visuals and spot-on specifications. It's like seeing your dream space wink at you before it's built.



### Project Execution

Project execution guided by clarity, craftsmanship, and absolute reliability. A minimal, premium approach that ensures every element falls perfectly into place.

## Our Expertise

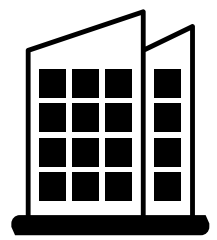

### Commercial

Creating office workplace to enhance the productivity. Our clients can choose from our wide range of desking, seating, cabinets, conference tables & trusted many more from our furniture partners worldwide.



### Healthcare

We offer best-in-class healthcare furniture solutions, we cater high-quality medically approved products to provide the comfort, elegant design and durability.

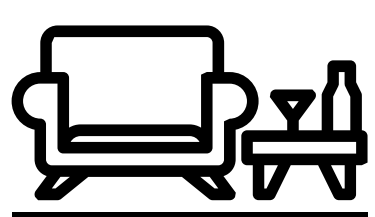

### Hospitality

We develop & implement a well disciplined turnkey furniture solution in all aspects of space planning, designing & installation and making your dream project a grand success.

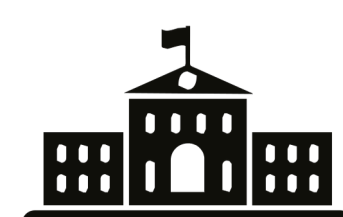

### Education

We design and cater complete education furniture to enhance the learning spaces to transform into an innovative & collaborative environment. We offer versatility & high quality service throughout all levels of education.

# SPC TILES – SPECIFICATIONS

- Thickness: 3.5mm to 8mm
- Wear Layer: 0.3mm to 0.7mm
- Beveling – Micro / Painted
- Backing: IXPE/ EVA/ FOAM
- Length: 12 inches (minimum) to 90 inches (maximum)  
Width: 5.9 inches (minimum) to 24 inches (maximum)
- Regular embossing  
EIR embossing

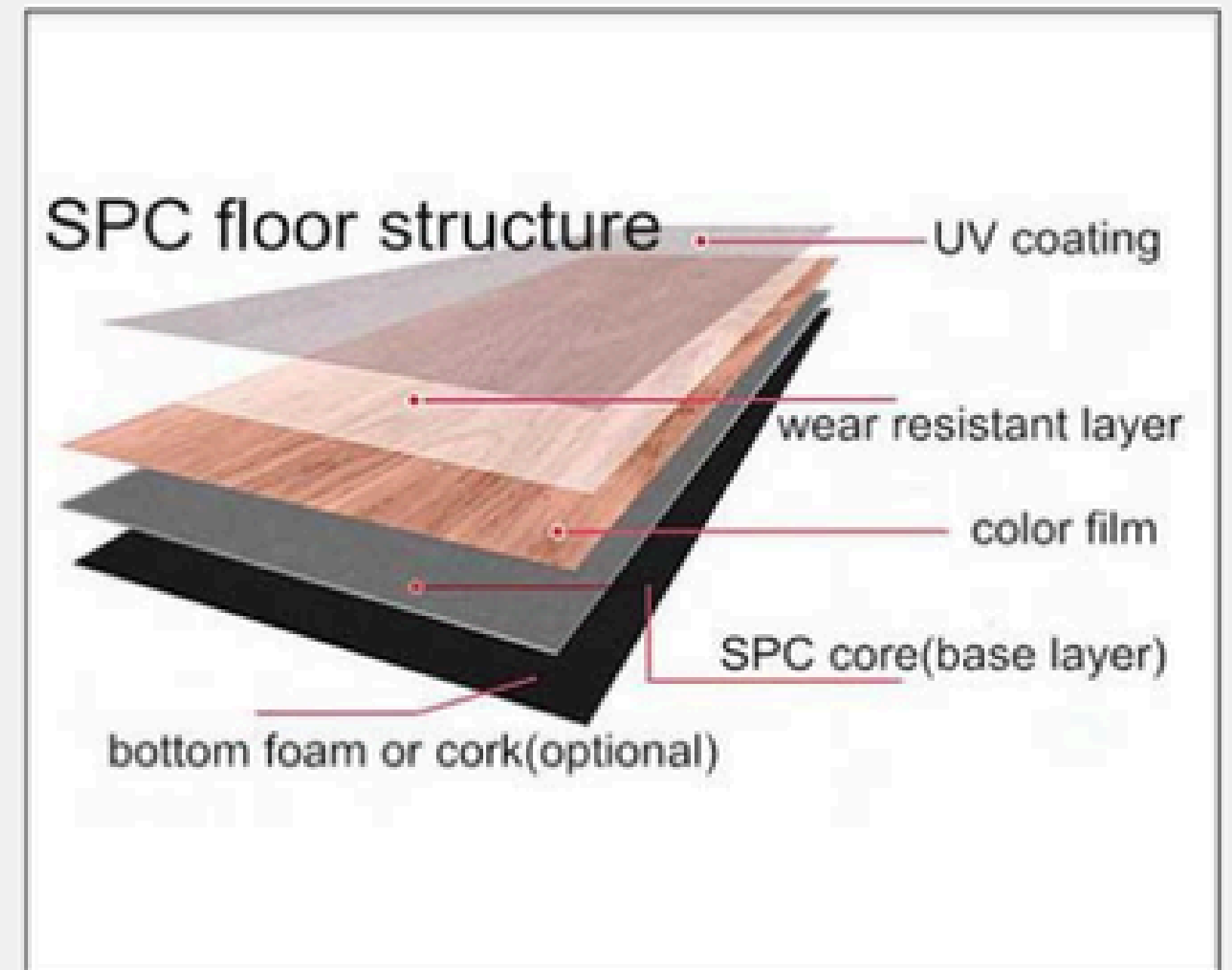

**UNICLIC**

# LUXURY VINYL TILES – SPECIFICATIONS

- Planks / Tiles – Dry Back / Click & Lock
- High Density PU coating and UV Coating
- Length: 1219.2mm – 1220mm / 600mm  
Width: 180mm – 228mm / 600mm
- Wear Layer: 0.3mm to 0.7mm
- Thickness: 3mm to 5mm
- Fire resistant and Environmental friendly.

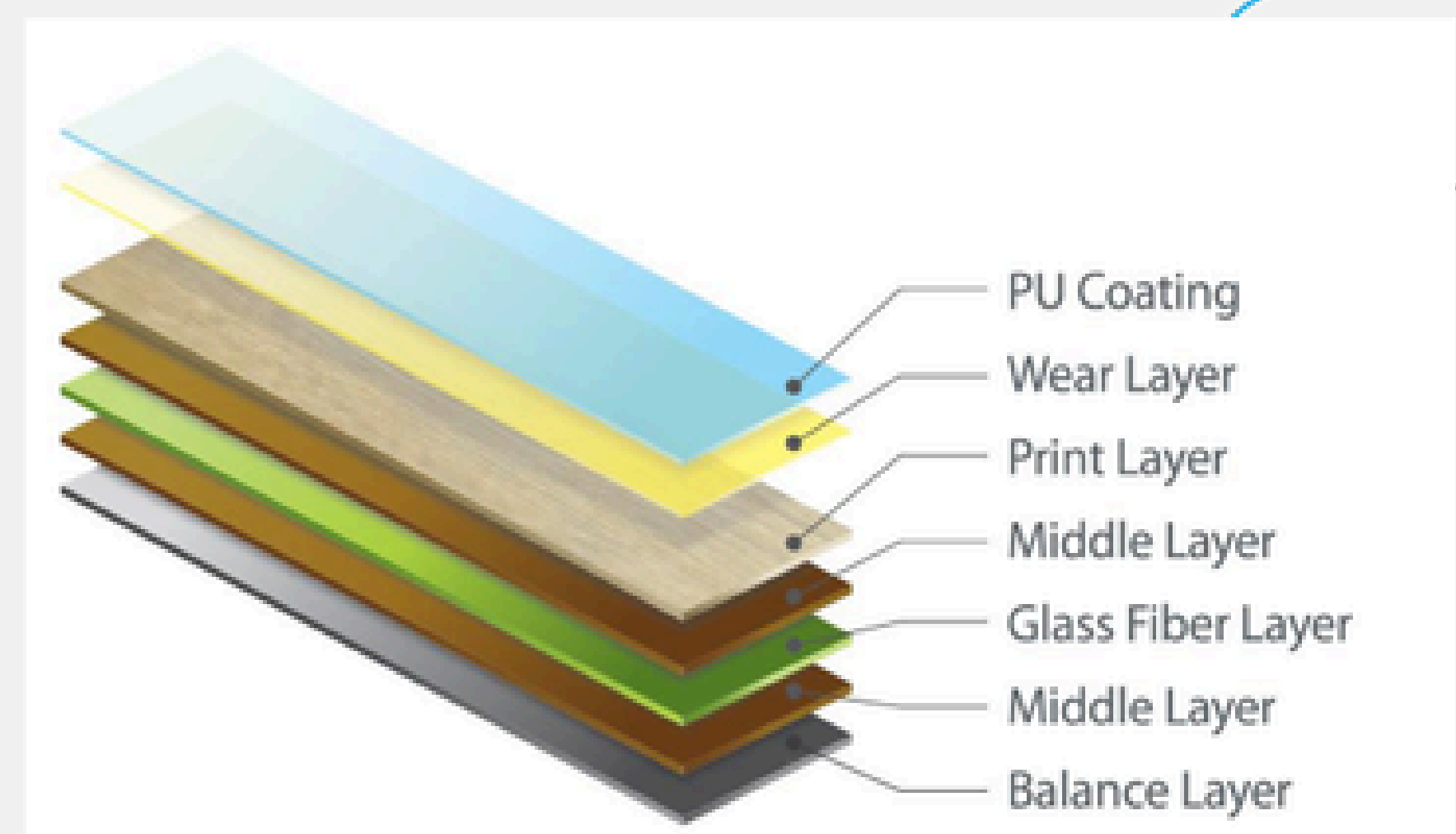

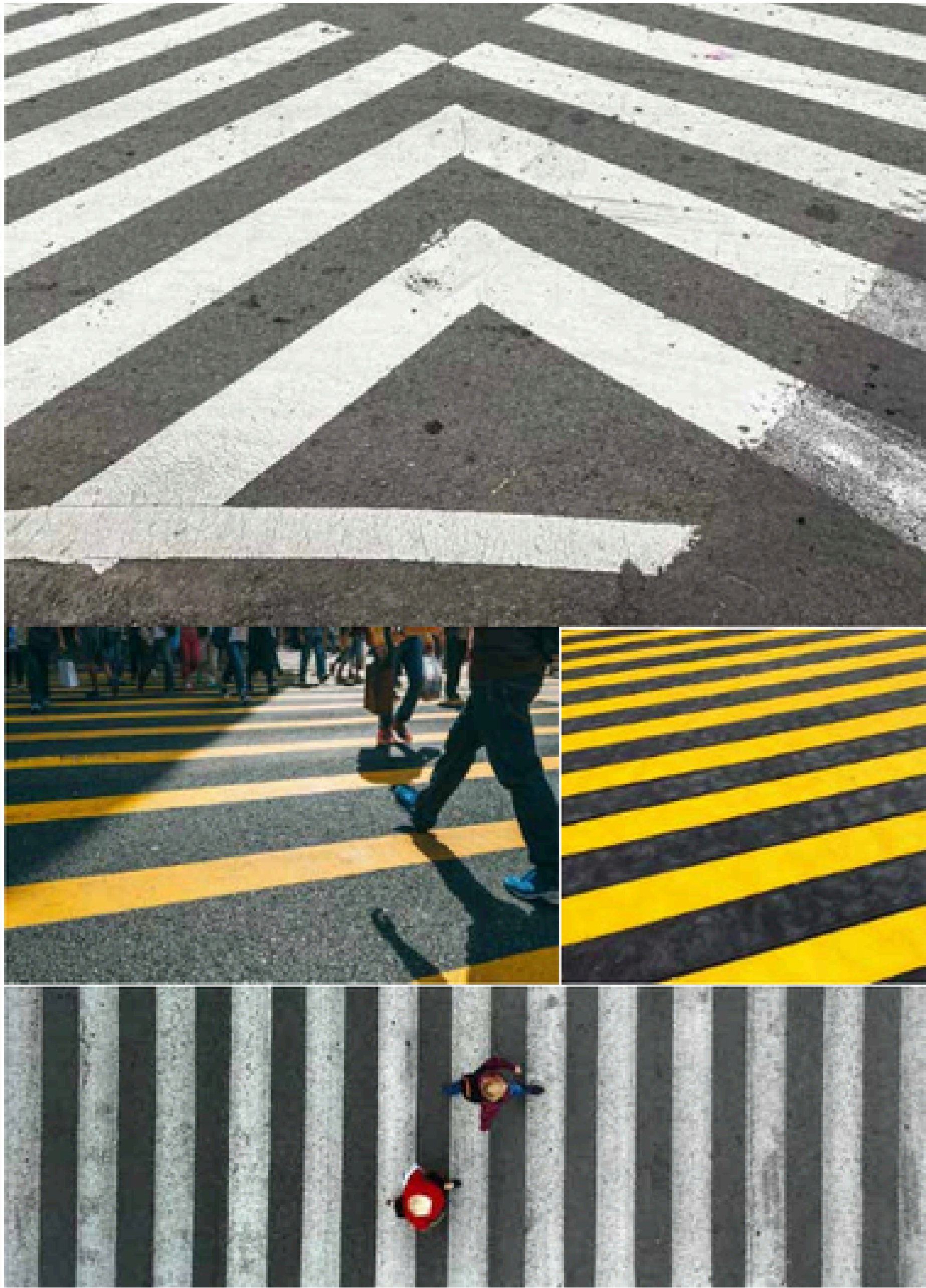

# SAVY STREET

Introducing Carpet Collection,  
 where urban sophistication meets contemporary style.  
 Inspired by the dynamic energy and vibrant spirit of city  
 life, each carpet in this collection showcases a modern  
 interpretation of classic stripe designs.

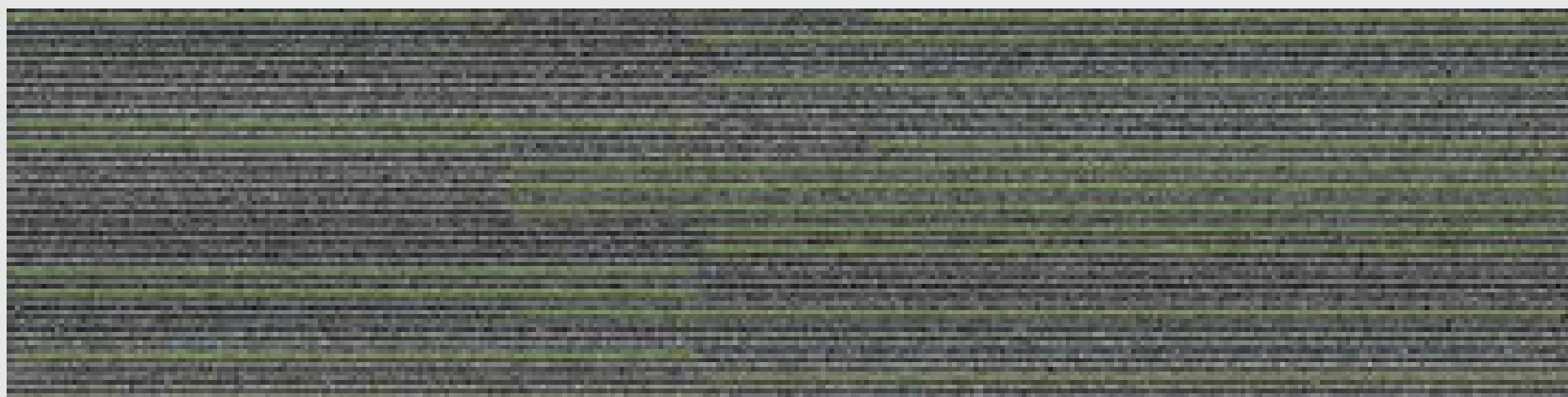

FOREST GREEN | CTY00231

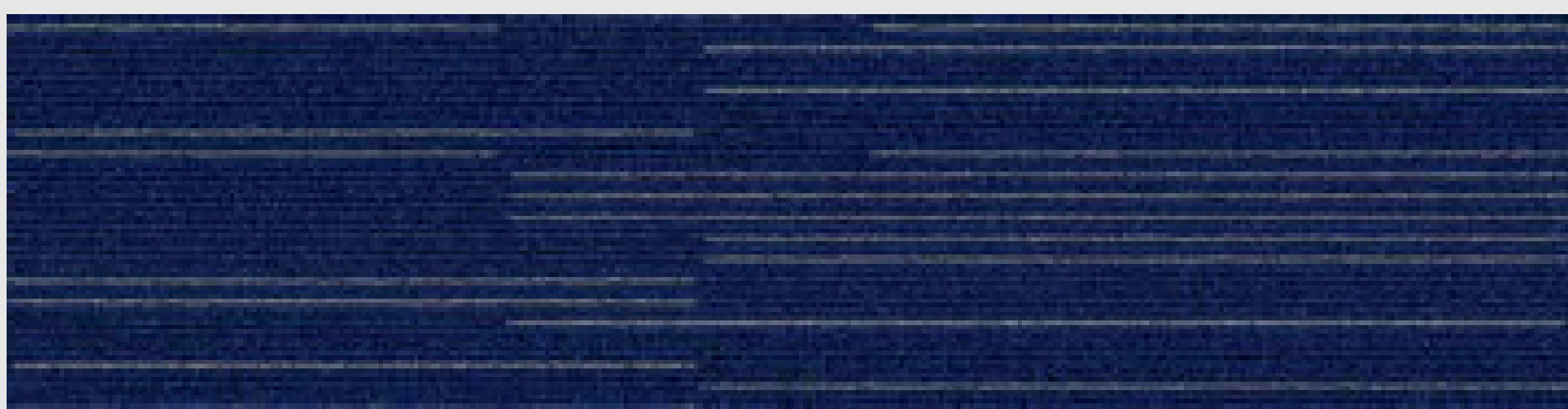

DARK GREY BLUE | CTY00225

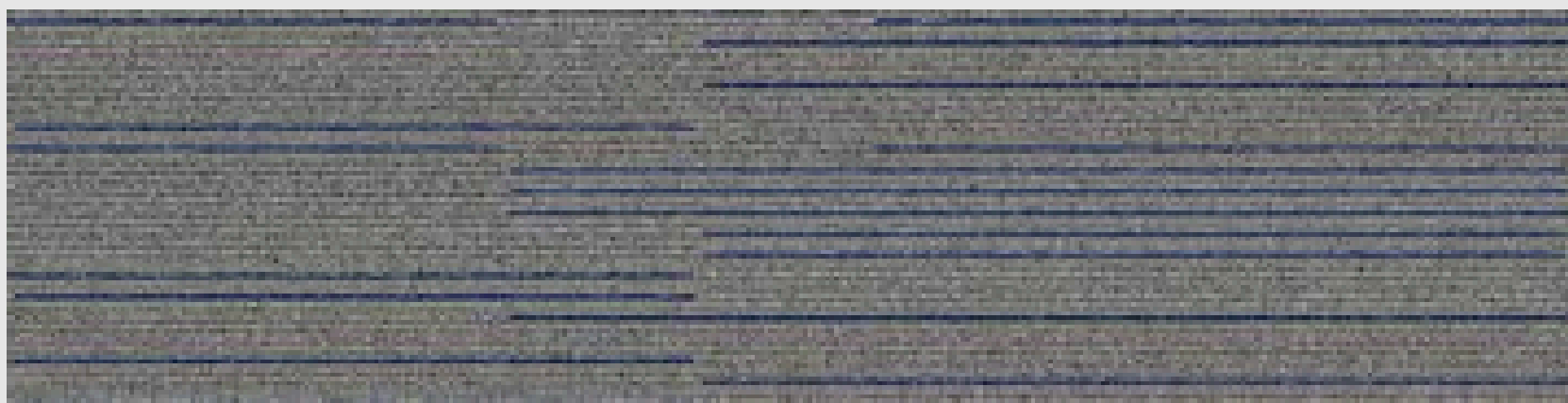

NAVY BLUE | CTY00226

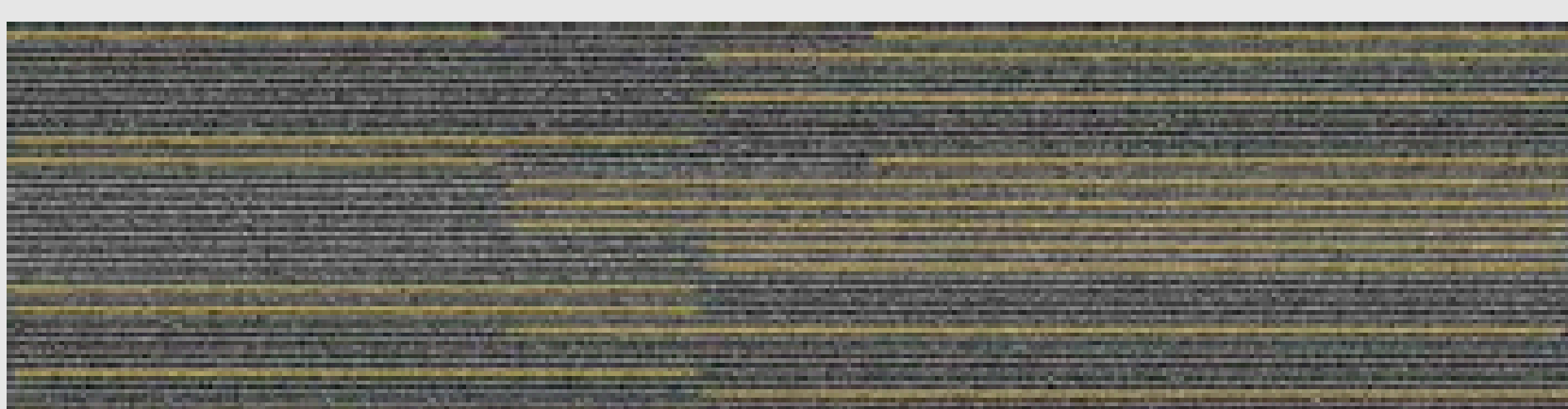

MUSTARD YELLOW | CTY00230



BROWN | CTY00229

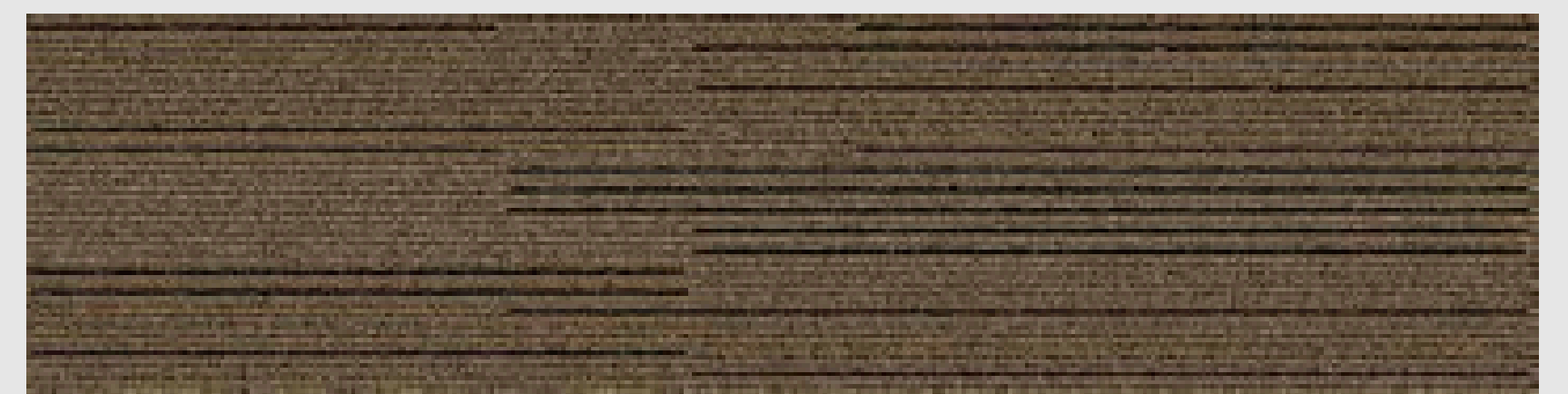

DARK GREY BROWN | CTY00228



DOVE GREY | CTY00227



DARK GREY | CTY00232

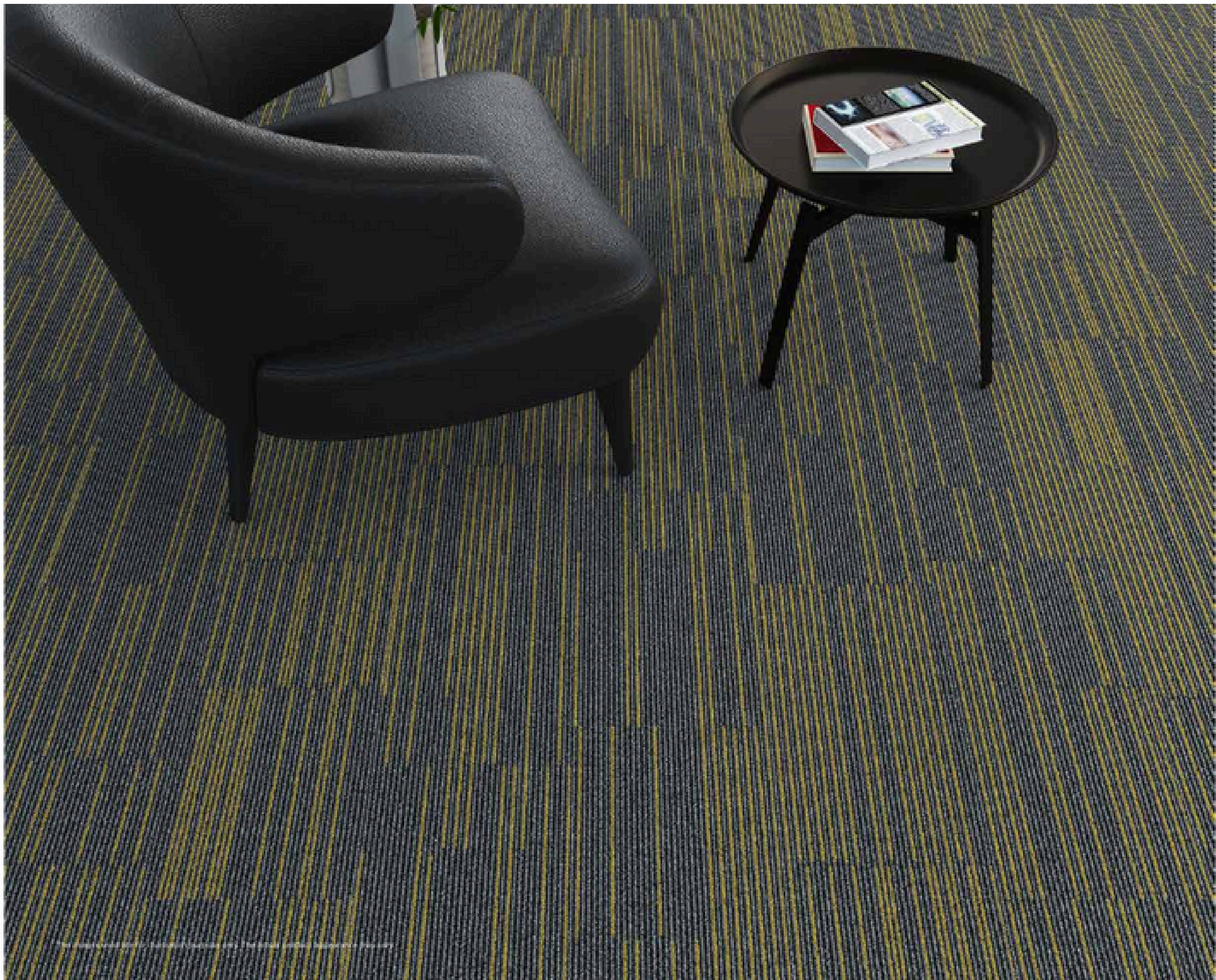



FOREST GREEN  
CTY00231

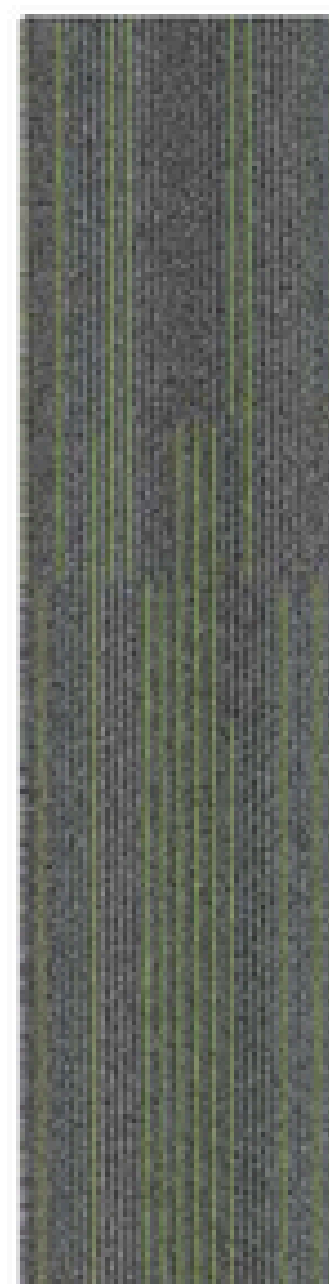

RANDOM VERTICAL BRICK

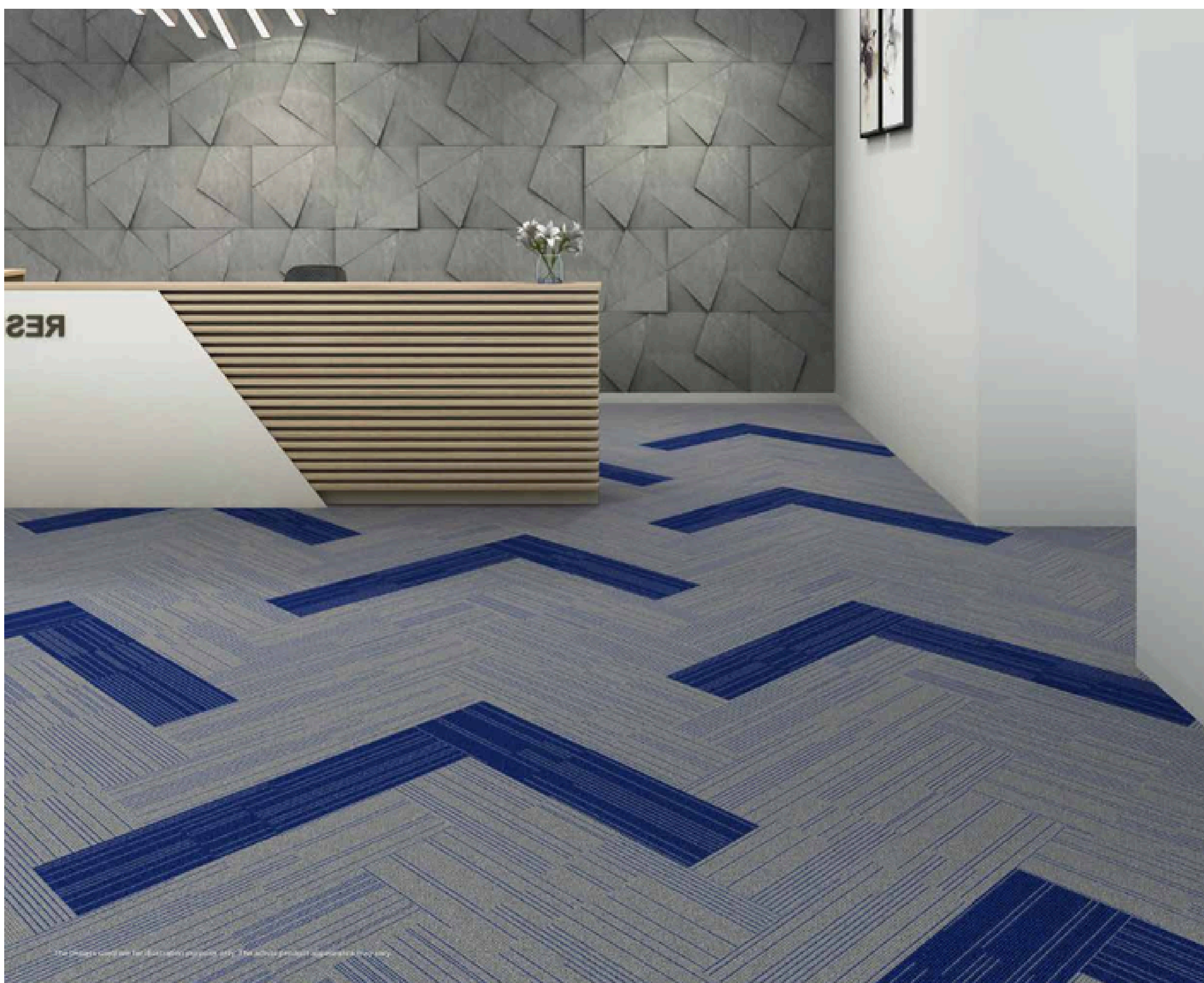
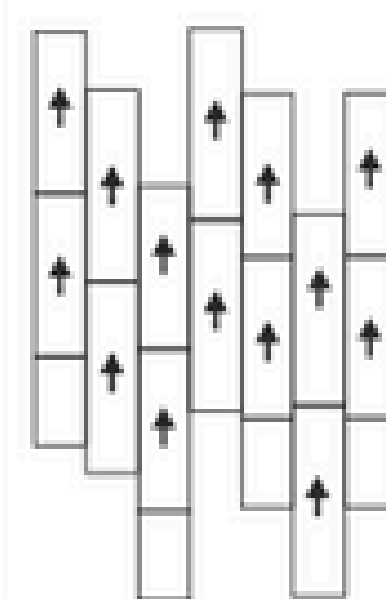

DARK GREY BLUE  
CTY00225

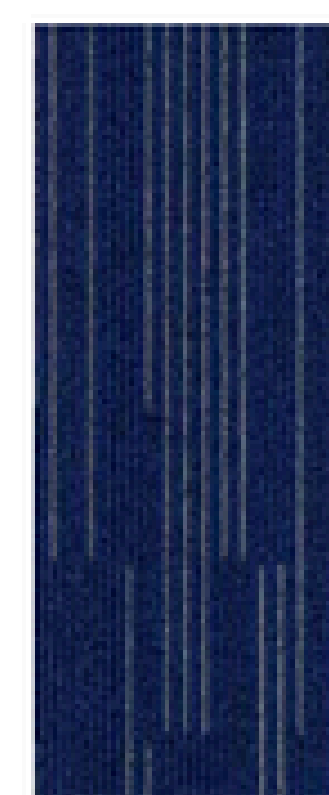

GREY  
CTY00227

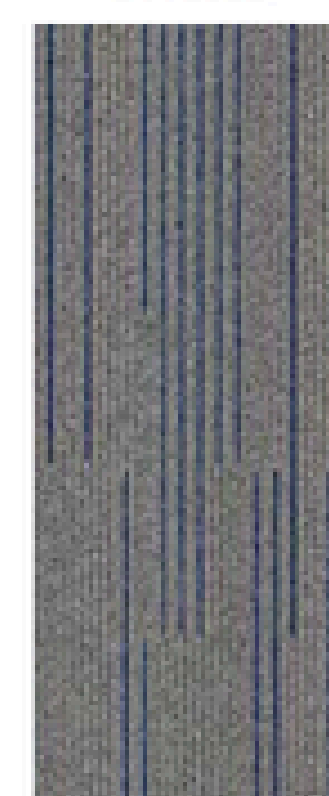

HERRINGBONE

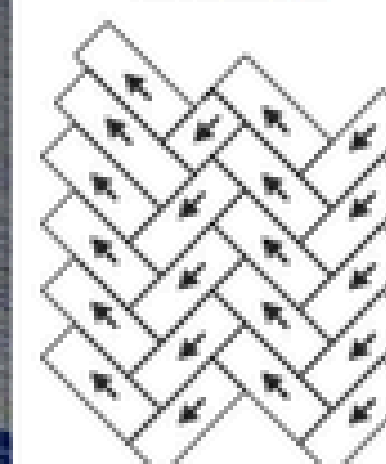



BROWN  
CTY00229



RANDOM VERTICAL BRICK

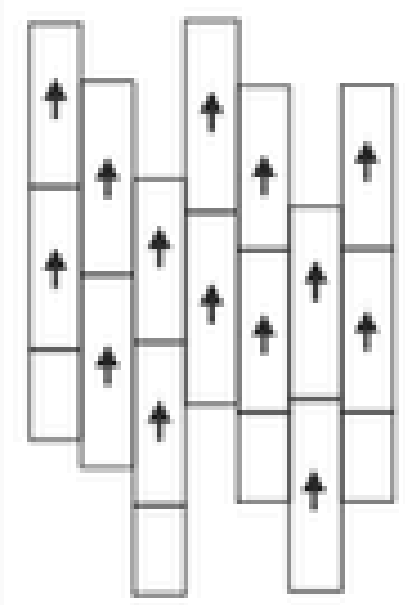

The images used are for illustrative purposes only. The actual product appearance may vary.



DOVE GREY  
CTY00227

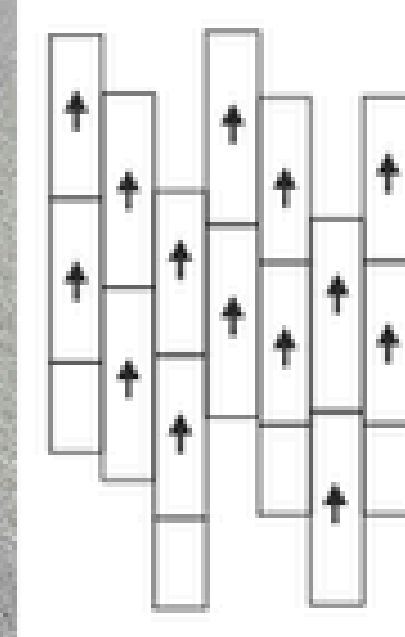
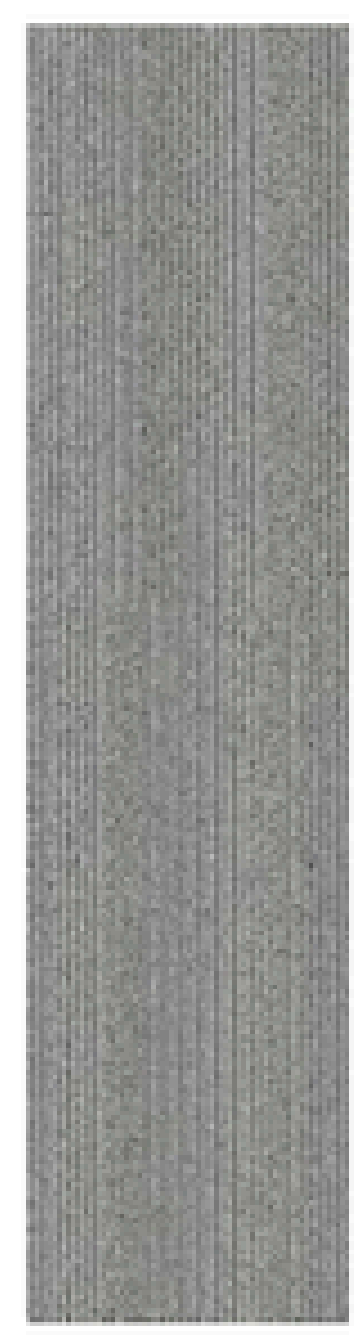

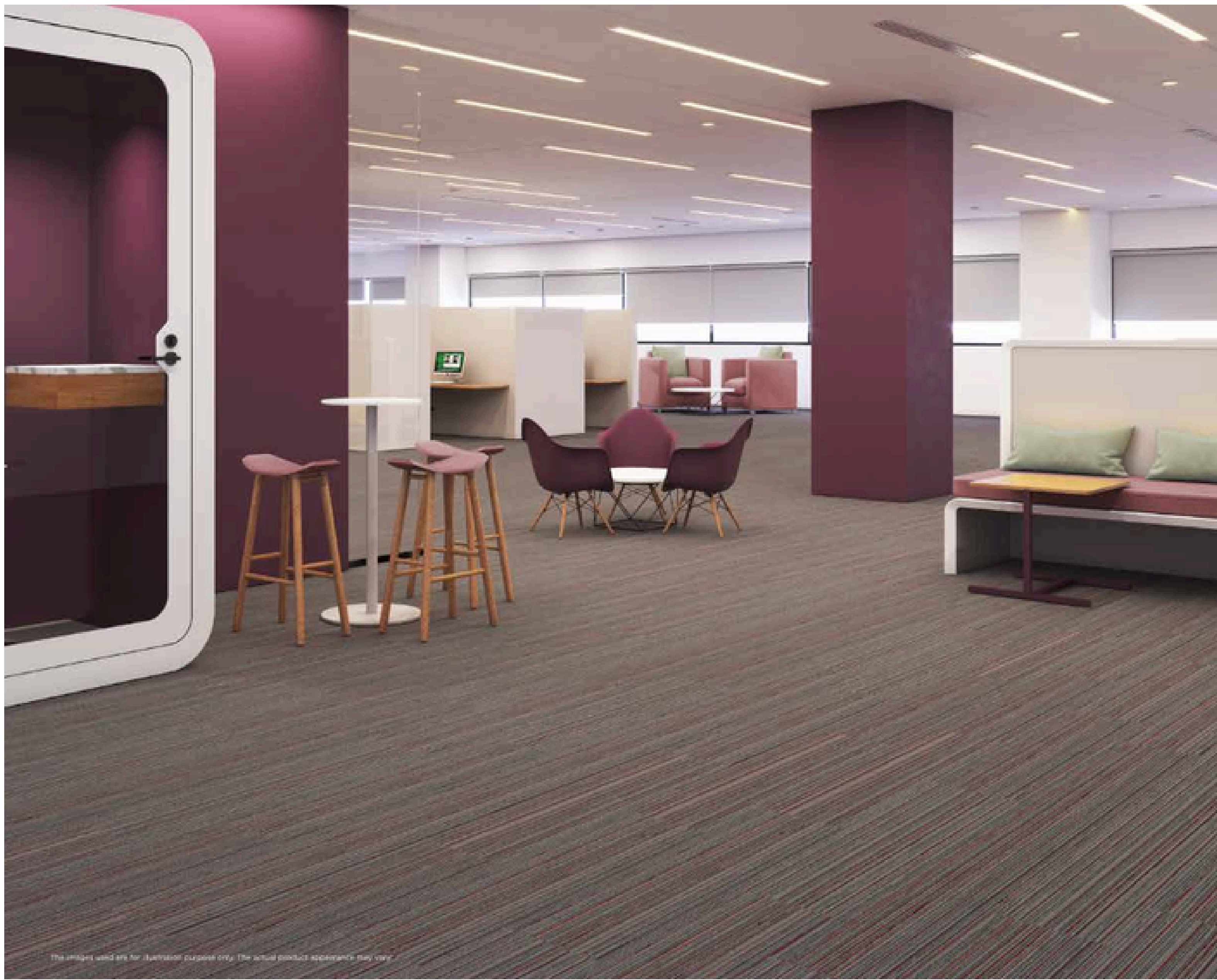

The images used are for illustrative purposes only. The actual product appearance may vary.

RED  
CTY00222

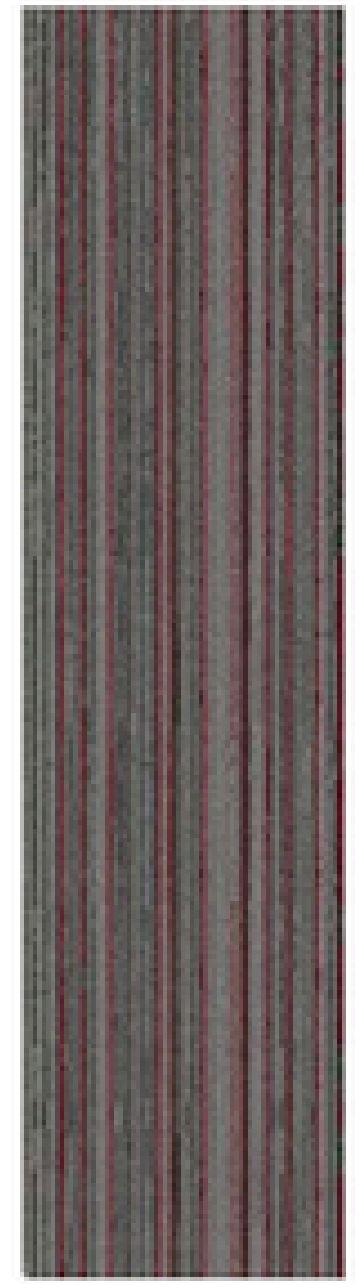

RANDOM VERTICAL BRICK

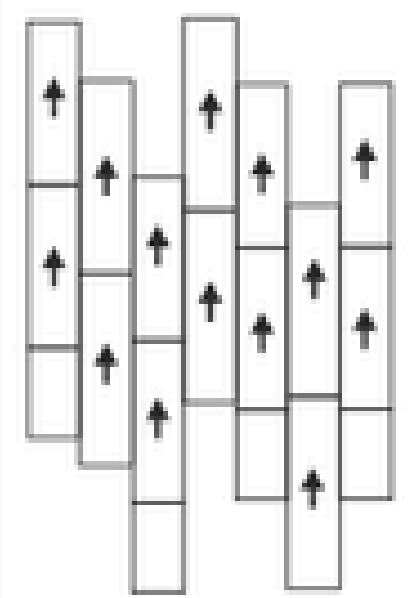

The images used are for illustrative purposes only. The actual product appearance may vary.

BLUE  
CTY00221

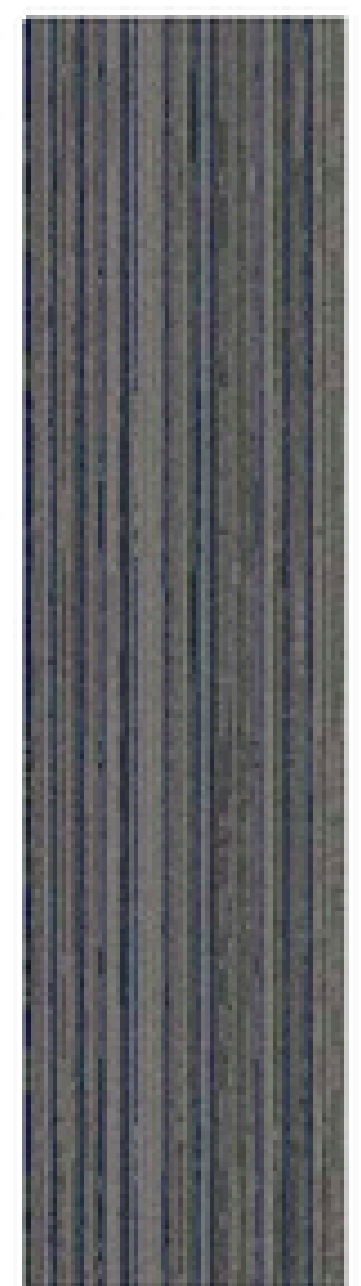

HERRINGBONE

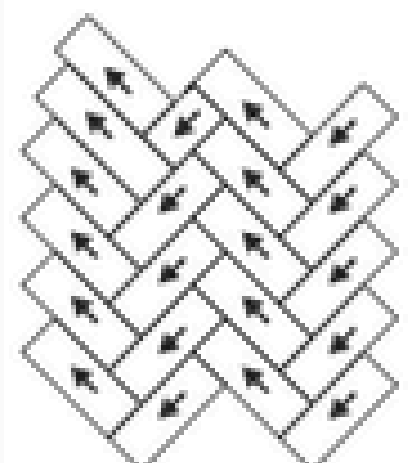

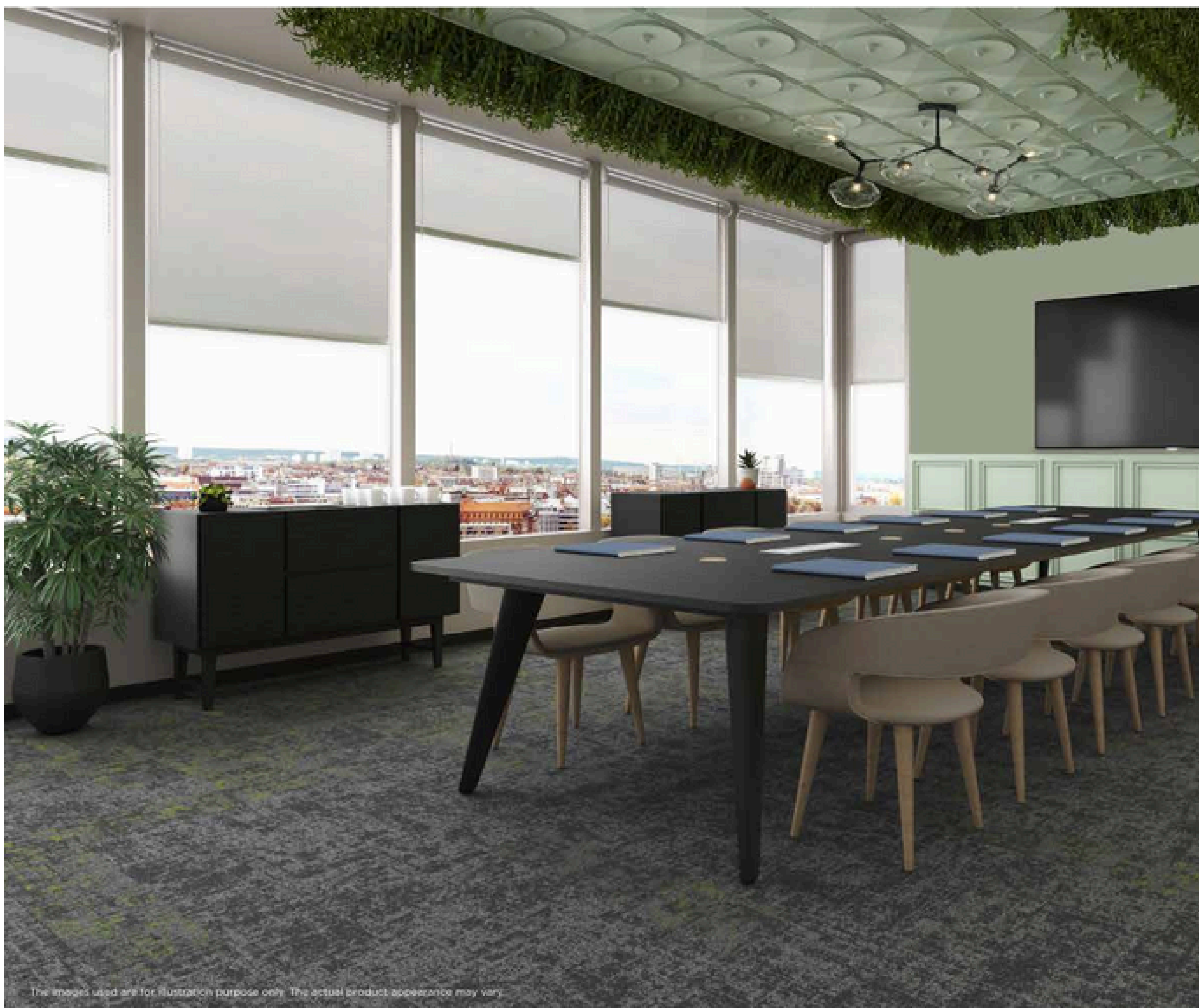
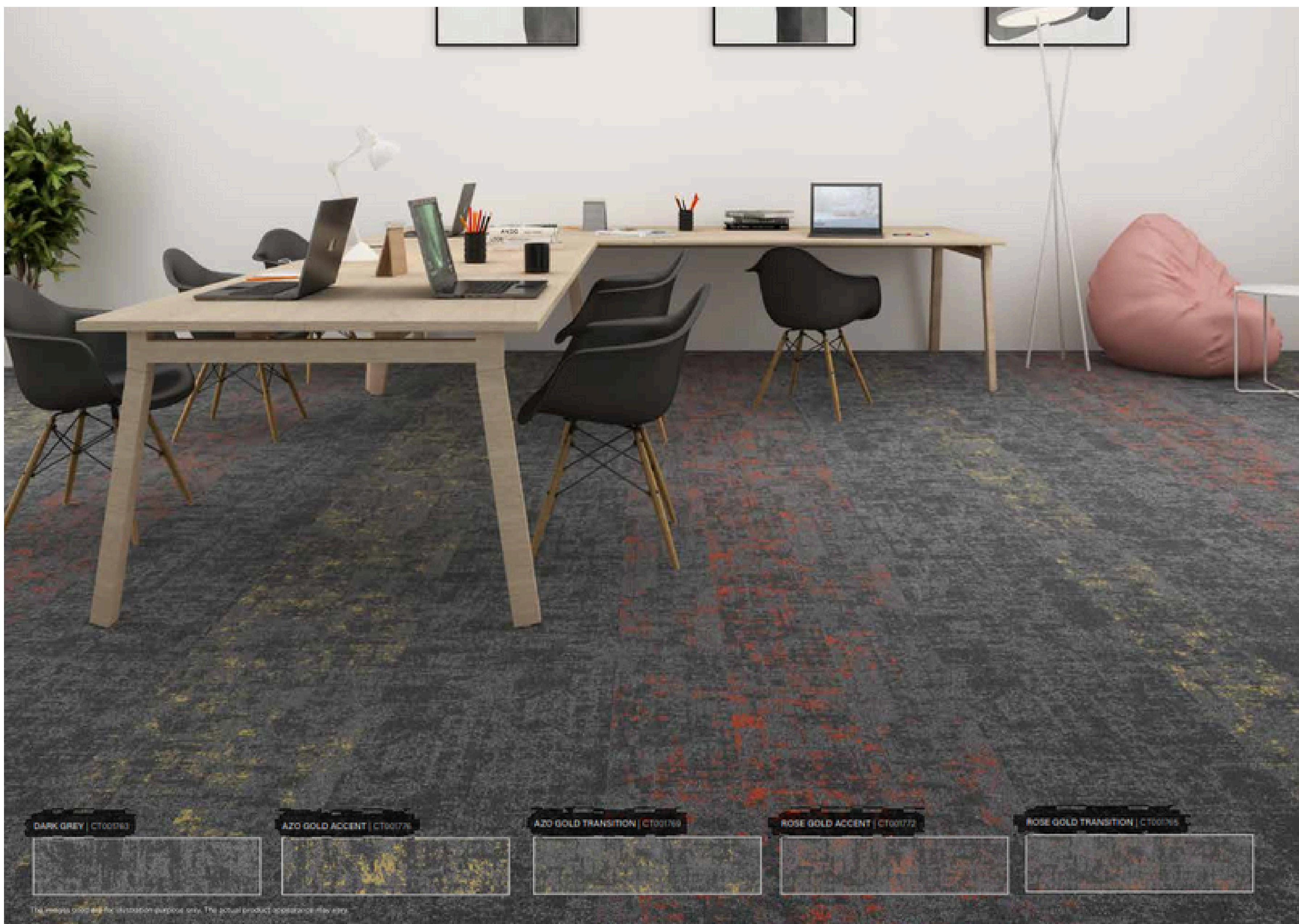



The images used are for illustration purpose only. The actual product appearance may vary.

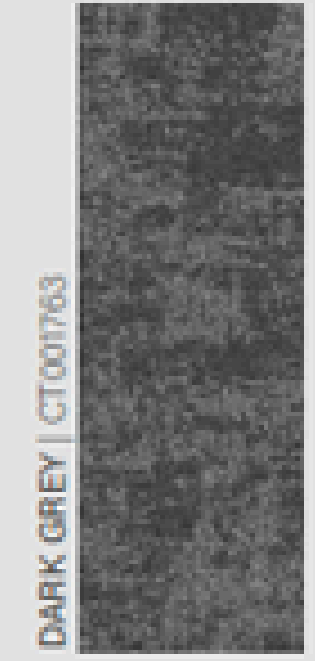

RANDOM VERTICAL BRICK

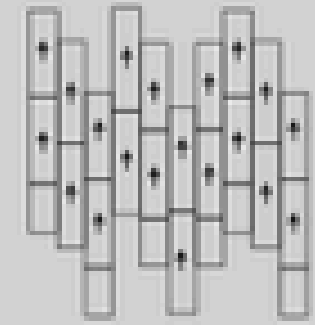

### PRODUCT SPECIFICATION

Types of color pattern	Grey	Transition	Accent
No. of Articles	2	7	7
Yarn	100% Solution Dyed Nylon (NY6+)	100% Solution Dyed Nylon (NY6+)	100% Solution Dyed Nylon (NY6+)
Machine Gauge	1/12 loop color point	1/12 loop color point	1/12 loop color point
Size in cm	25x100	25x100	25x100
Pile Thickness mm	3.0-4.0	3.5-4.5	4.0-5.0
Total Thickness mm	5.0-6.0	5.5-6.5	6.0-7.0
Density	5200	5200	5500
SPI	14	20	21
Tufting Weight (Oz)	20	24	26
Backing System	Welspun Ecolite or Comfortile	Welspun Ecolite or Comfortile	Welspun Ecolite or Comfortile
Indicates	+/- 5%	+/- 5%	+/- 5%

### TEST REPORT SUMMARY

Test Name	Method	Test Name	Method
Anti Microbial Treatment	AATCC 174 (Part II & III)	Colour fastness to bleach	AATCC 6
Delamination	ASTM D 3936	Static Electricity	AATCC 134-1996
Tuft Bind	ASTM 1535-67	Anti Static	ANSI/ESD S 7.1
Dimensional stability	ASTM D 7570	Castor Chair	DIN 54324
Pile weight	ASTM D 5848-07	Hexapod	ASTM D 5252-15
Pile density	ASTM D 5848-07	Static Coefficient	ASTM C 1028
Total thickness	ASTM D 6988-08	Dimensional stability (Aachen test)	DIN-STD-54318/ITTS-004
Pile height	ASTM D 5823-05a	Anti Soil	ASTM D 6540-05
Gauge	ASTM D 5793-13	Shampoo Fastness	AATCC 138
Tuft density	ASTM D 5848	Water Fastness	AATCC 107
Flammability (Pill Test)	ASTM D 2859	Velcro-Loops	ITTS 112
Flammability (Radiant Panel)	ASTM E 2859-06	Heavy Traffic test (Walk test)	ASTM 6119-03
NBS Smoke Density (Flaming)	ASTM E 642-06	Sound transmission	ASTM C 425-17
Lightfastness	AATCC 16 E	Sound Absorption	ASTM C 425-17
Colour fastness to Ozone	AATCC 129	Static Loading	ISO 015/3415
Colour fastness to NO <sub>2</sub>	AATCC 164-2008	Green Carpet (VOC)	ASTM D 5116
Crocking Dry and Wet	AATCC 165-2008	Acoustic	BS EN ISO 354
Stain fastness	AATCC 175-2008/ITTS 002	Thermal Resistance	ASTM C 518

### CARPET TILES ADVANTAGES

- Solution Dyed Nylon
- Multiple Design Possibilities
- Ideal For Heavy Foot Traffic
- Stain Protect
- Offers Sound Absorption
- Reduce Wasteage During Installation
- 40% Lesser Environment Footprint
- Fade Resistant
- Less Lead Time
- Easy To Maintain
- Easy To Install
- Made in India

### CERTIFICATION

- GreenGuard Gold
- GreenGuard Plus
- Verified Environmental Product Declaration
- GreenFiber
- Zero Waste
- CE
- GreenMark
- SGS
- OEKO-TEX STANDARD 100
- OEKO-TEX STeP
- ISO 9001:2015 CERTIFIED
- ISO 14001:2015 CERTIFIED
- ISO 45001:2018 CERTIFIED

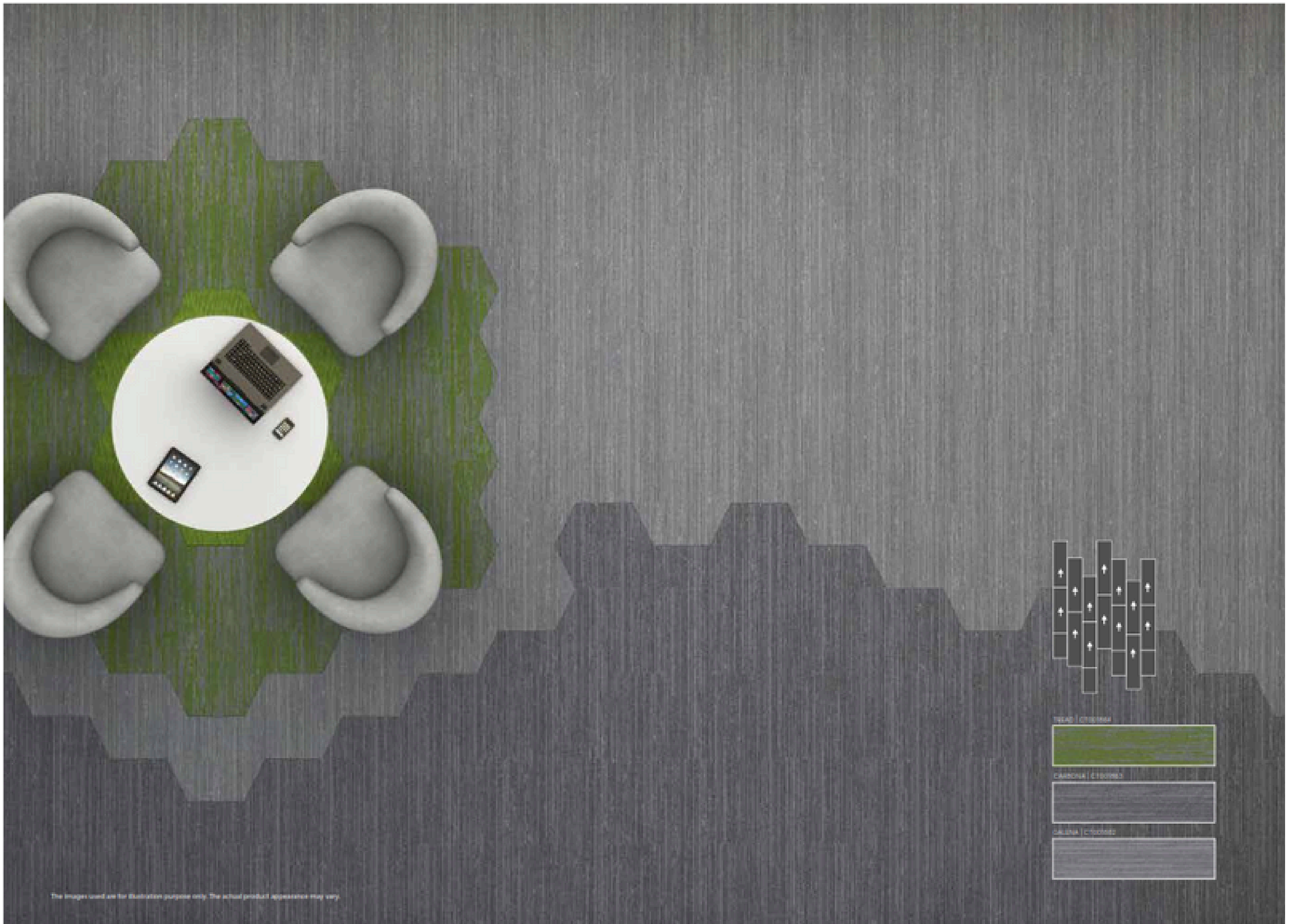

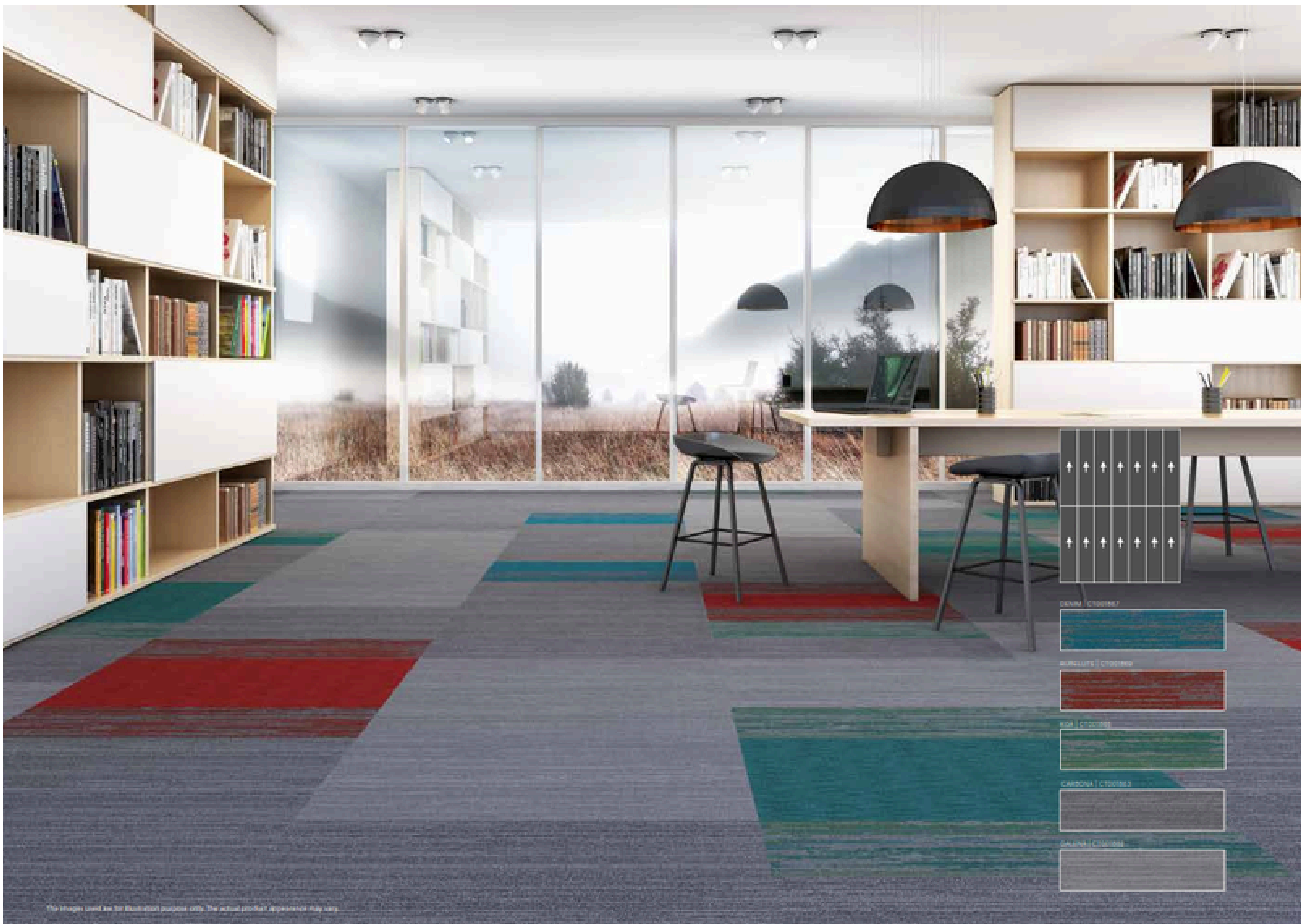
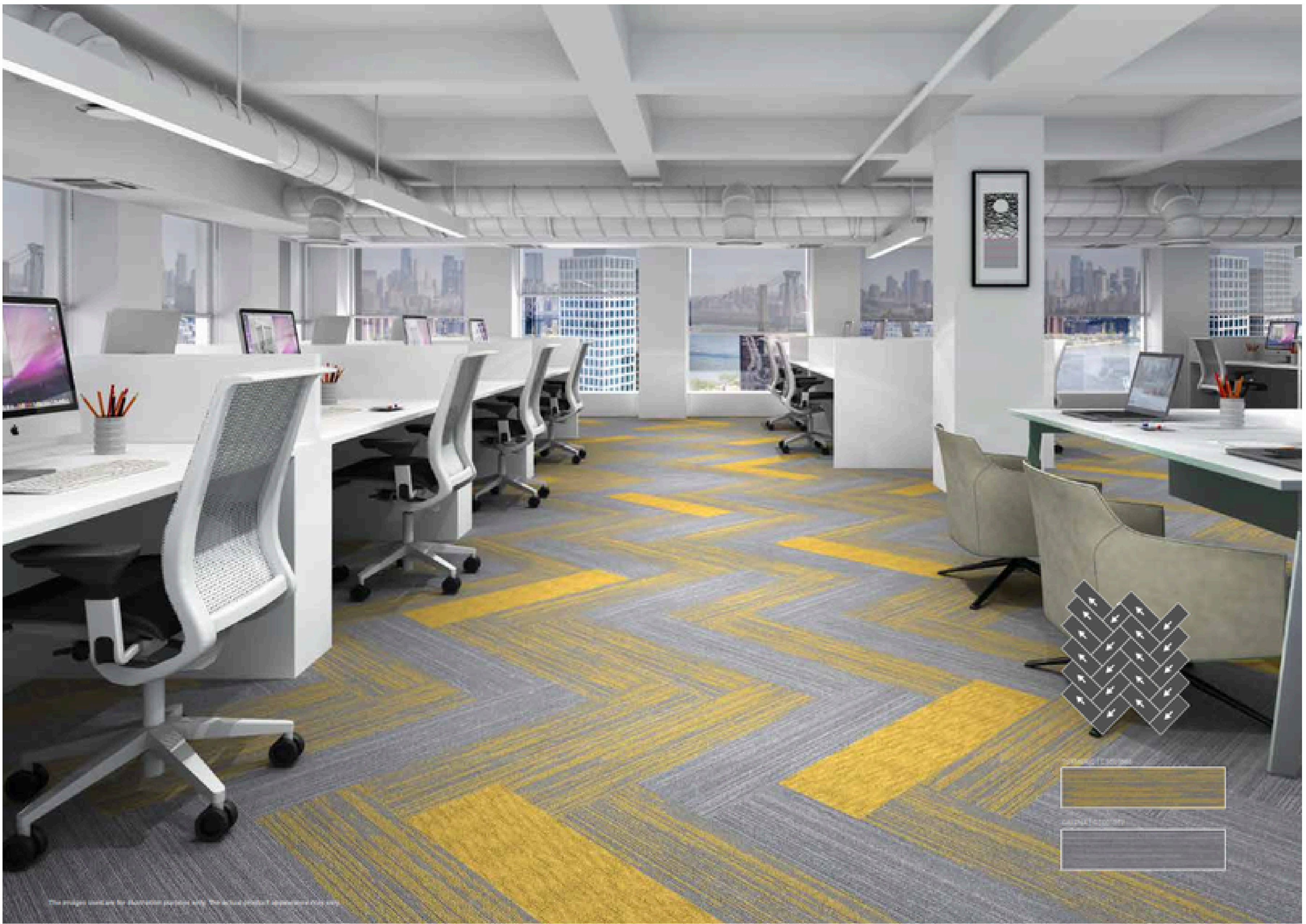

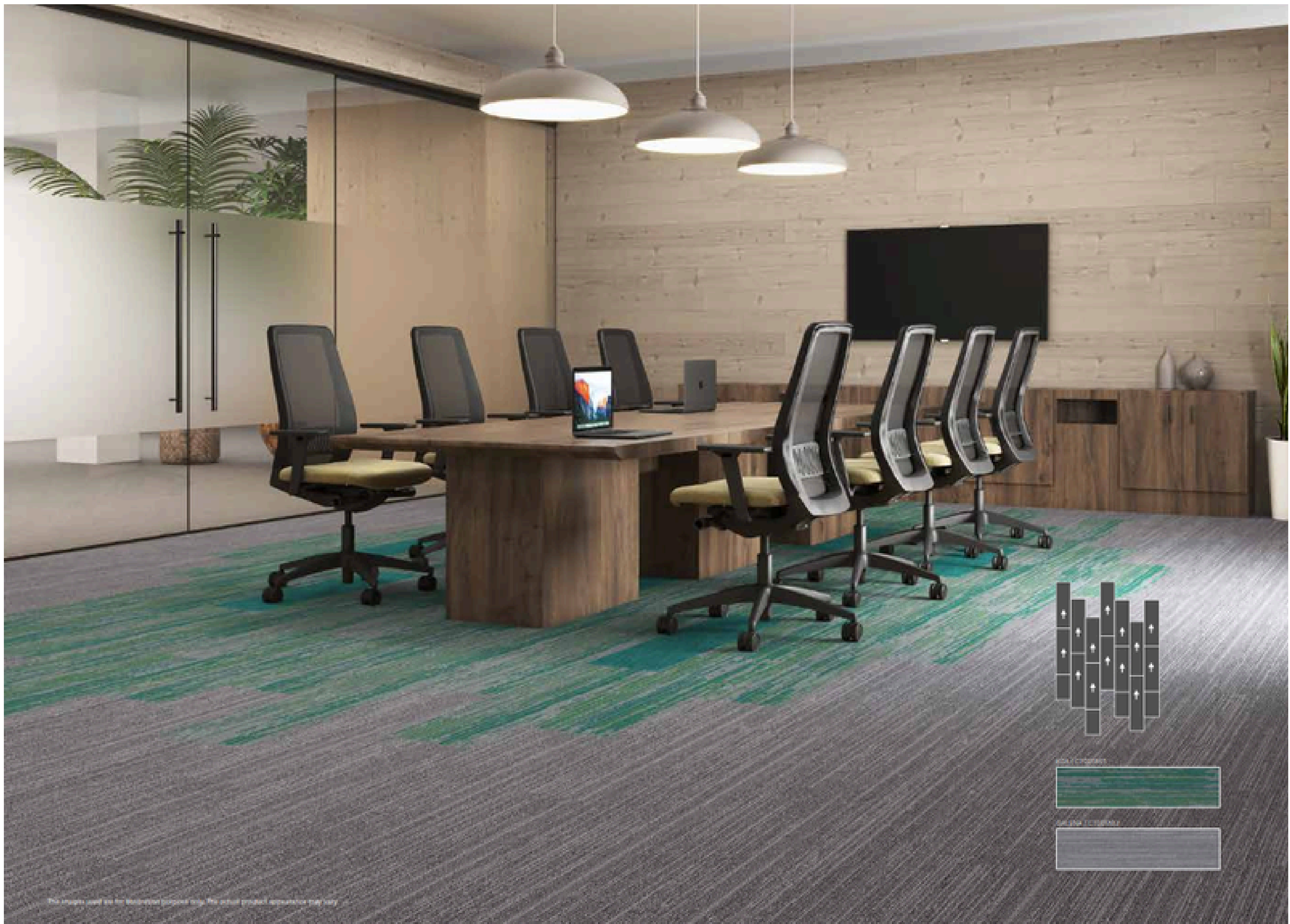

## Carpet Tiles Advantages



## Product Specification

Program Name	Woodland
Machine Gauge	1/10 Loop Infinity
Yarn	100% Solution Dyed Nylon (NY6+)
Size (CM)	25x100 CM
Pile Height	3.0-3.5 mm
Total Thickness	5.0-5.5 mm
Density	4200
SPI	10
Tufting Weight (Oz)	14
Backing System	Welspun Ecolite or Comfortile
Indicates	+/- 5%

## Trademarks & Technologies

- Welspun Ecolite™**  

Welspun Ecolite™ backing are made up of lightweight PVC that not only reduces the overall weight significantly but ensures a 40% lower environmental footprint than traditional carpets. Despite that, this backing retains the highest performance standards.
- Now also available with Healthy Floor™ (Optional).**  

We also have carpet tile options with antiviral properties. Tested and certified by Reslnova Labs, we are India's first antiviral carpet tiles. It kills 99.68% of human coronavirus due to a special coating of silver iron & titanium oxide. We make healthy floors.
- Comfortile™M (Optional).**  

With Comfortile™ backing, our tiles come with a customized felt-back that not only offers great underfoot comfort but also sound absorption. Comfortile™ provides extra levels of protection and support for high levels of acoustic and ergonomic comfort.
- NY6+™**  

For colors that don't fade out, Welspun Floorings Ny6+™ is made up of a highly resilient fiber that is known for its superior colour retention, strength, stain and fade resistance. With all this, your floor always retains its beauty come what may.

## Test Report Summary

Test Name	Method	Test Name	Method
Anti Microbial Treatment	AATCC 174 (Part II & III)	Colour fastness to bleach	AATCC 6
Delamination	ASTM D 3936	Static Electricity	AATCC 134-1996
Tuft Bind	ASTM 1335-07	Anti Static	ANSI/ESD S 7.1
Dimensional stability	ASTM D 7570	Castor Chair	DIN 54324
Pile weight	ASTM D 5848-07	Hexapod	AST D 5252-15
Pile density	AST D 5848-07	Static Coefficient	ASTM C 1028
Total thickness	ASTM D 6988-08	Dimensional stability (Aachen test)	DIN-STD-54318/ITTS-004
Pile height	ASTM D 5823-05a	Anti Soil	ASTM D 6540-05
Gauge	ASTM D 5793-13	Shampoo Fastness	AATCC 138
Tuft density	ASTM D 5848	Water Fastness	AATCC 107
Flammability (Pill Test)	ASTM D 2839	Velcro-Loops	ITTS 112
Flammability (Radiant Panel)	ASTM E 648-00	Heavy Traffic test (Walk test)	AST 6119-03
NBS Smoke Density (Flaming)	ASTM E 662-00	Sound transmission	ASTM C 423-17
Lightfastness	AATCC 16 E	Sound Absorption	ASTM C 423-17
Colour fastness to Ozone	AATCC 129	Static Loading	ISO 015/3415
Colour fastness to NO <sub>2</sub>	AATCC 104-2008	Green Carpet (VOC)	ASTM D 5116
Crocking Dry and Wet	AATCC 105-2008	Acoustic	BS EN ISO 354
Stain fastness	AATCC 173-2008/ITTS 002	Thermal Resistance	ASTM C 518

## Certification



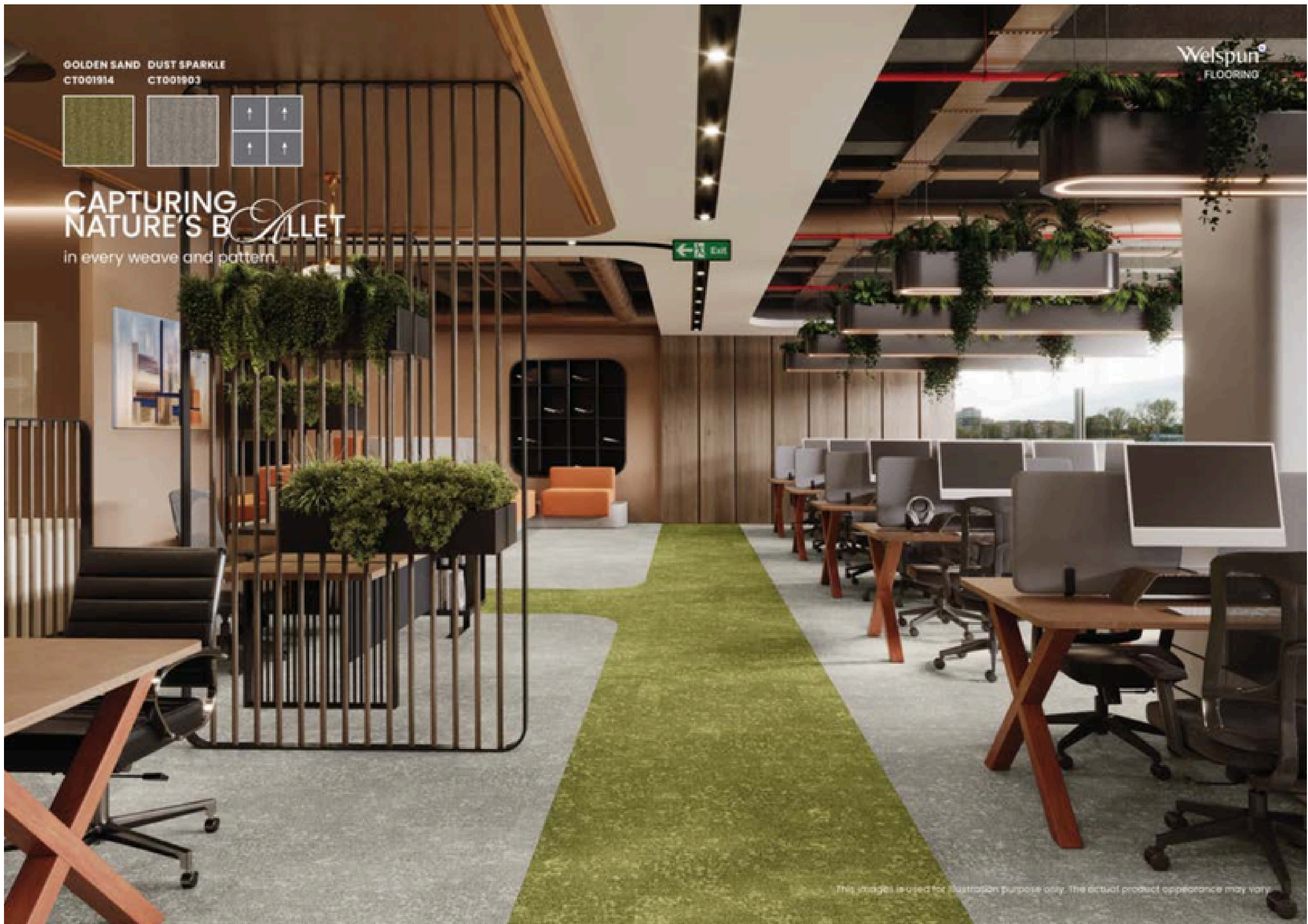



Since its inception in 1985, the Welspun Group has been committed to making India proud globally through its superior quality and innovative products and services. Its brilliant addition, Welspun Flooring, now has a modern manufacturing facility spread over an impressive 300 acres with an investment of more than 1150 cr. A break through in engineering and design, Welspun Flooring brings you a unique meeting of form and function in each collection. This distinctive quality appeals to Architects, Designers, Retailers and Consumers, offering them holistic flooring solutions that spur creative thinking and an elevated sense of design.

**TEST REPORT SUMMARY**

Test Name	Method	Test Name	Method
Anti Microbial Treatment	AATCC 174 (Part II & III)	Colour fastness to bleach	AATCC 6
Delamination	ASTM D 3936	Static Electricity	AATCC 134-1996
Tuft Bind	ASTM 1335-67	Anti Static	ANSI/ESD S 7.1
Dimensional stability	ASTM D 7570	Castor Chair	DIN 54324
Pile weight	ASTM D 5848-07	Hexapod	ASTM D 5252-15
Pile density	ASTM D 5848-07	Static Coefficient	ASTM C 1028
Total thickness	ASTM D 6968-08	Dimensional stability (Aachen test)	DIN-STD-54318/ITTS-004
Pile height	ASTM D 5823-05a	Anti Soil	ASTM D 6540-05
Gauge	ASTM D 5793-13	Shampoo Fastness	AATCC 138
Tuft density	ASTM D 5848	Water Fastness	AATCC 107
Flammability (Pill Test)	ASTM D 2859	Velcro-Loops	ITTS 112
Flammability (Radiant Panel)	ASTM E 648-06	Heavy Traffic test (Walk test)	ASTM 6119-03
NBS Smoke Density (Flaming)	ASTM E 662-06	Sound transmission	ASTM C 423-17
Lightfastness	AATCC 16 E	Sound Absorption	ASTM C 423-17
Colour fastness to Ozone	AATCC 129	Static Loading	ISO 015/3415
Colour fastness to NO <sub>2</sub>	AATCC 164-2008	Green Carpet (VOC)	ASTM D 5116
Crocking Dry and Wet	AATCC 185-2008	Acoustic	BS EN ISO 354
Stain fastness	AATCC 175-2008/ITTS 002	Thermal Resistance	ASTM C 518

**TRADEMARKS & TECHNOLOGIES**



**NY6+™**

For colors that don't fade out, Welspun Floorings Ny6+™ is made up of a highly resilient fiber that is known for its superior color retention, strength, stain and fade resistance. With all this, your floor always retains its beauty come what may.



**Welspun Ecolite™**

Welspun Ecolite™ backing are made up of lightweight PVC that not only reduces the overall weight significantly but ensures a 40% less environment footprint than traditional carpets. Despite that, this backing retains the highest performance standards.



**Comfortile+™ (Optional)**

With Comfortile+™, enjoy the most superior levels of safety, underfoot comfort and sound absorption. Equipped with a cushion back that is 20% more thicker, Comfortile+™ decreases sound reflection by 25% compared to hard back enabling you to enjoy quieter spaces which leads to better health.



**HealthyFloor™ (Optional)**

We also have carpet tiles options with antiviral property. Tested and certified by Resinova labs, we are the first company in India to offer antiviral carpet tiles. It eliminates 99.68% of virus thanks to a special coating of silver ion & titanium oxide.

**FEATURES**



Nylon Tufted Product

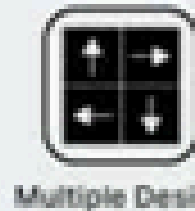

Multiple Design Possibilities

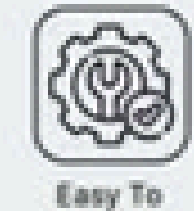

Easy To Install



Reduces Wastage During Installation



Easy To Maintain



Stain Resistance

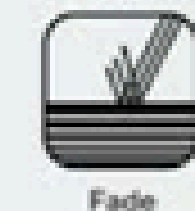

Fade Resistance



Ideal For Heavy Foot Traffic



**PRODUCT SPECIFICATIONS IN CARPET TILES**

Yarn	100% Solution Dyed Nylon (NY6+)
Machine Gauge	1/12 loop Infinity
Size in cm	50x50
Pile Thickness mm	3.5-4 mm
Total Thickness mm	5.5-6 mm
Density	4700
SPI	13
Tufting Weight (Oz)	18 oz
Backing System	Welspun Ecolite or Comfortile
Indicates	+/- 5%

\*Indicates +/-5%

**CERTIFICATIONS**



# FLOOR PLAY

COLOURWAYS

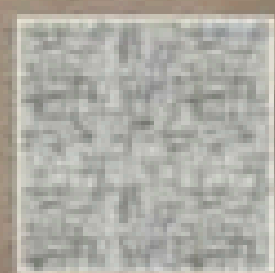

CHAMPAGNE SAND  
CP000196



ESPRESSO  
CP000198



SILVER MIST  
CP000199

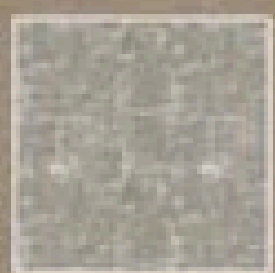

SUNLIT  
CP000200



MAHOGANY  
CP000203

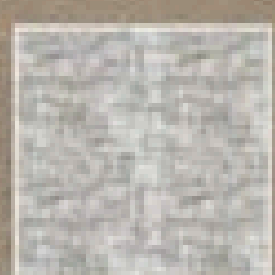

HUSH BEIGE  
CP000204



PEARL HAZE BEIGE  
CP000205



GOLDEN SAND  
STONE BEIGE  
CP000206



CHARCOAL SHADOW  
CP000201

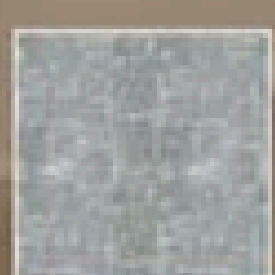

SYMPHONY  
CP000202



OCEAN GREY BEIGE  
CP000208



CARAMEL ELEGANCE  
CP000209

# INTRICATE

connections,  
turning floors into masterpieces.

ESPRESSO  
CP000198



CHAMPAGNE SAND  
CP000196

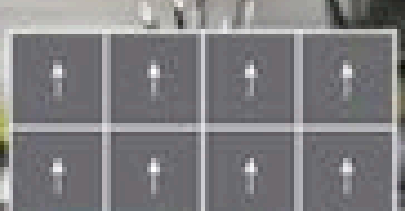
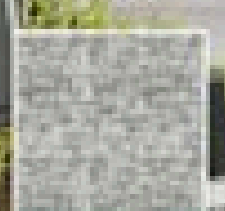



Welspun  
FLOORING

**LINES** meet, creating a mosaic of endless imagination and wonder.

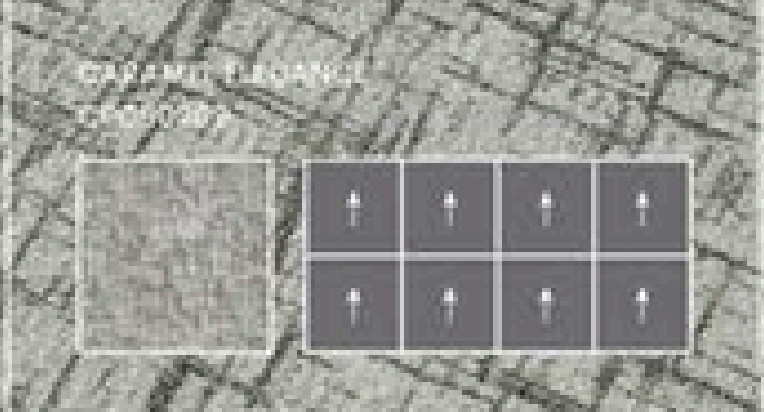

This image is used for illustration purpose only. The actual product appearance may vary.



Welspun  
FLOORING

**INTERWOVEN** paths, transforming ordinary floors into art.

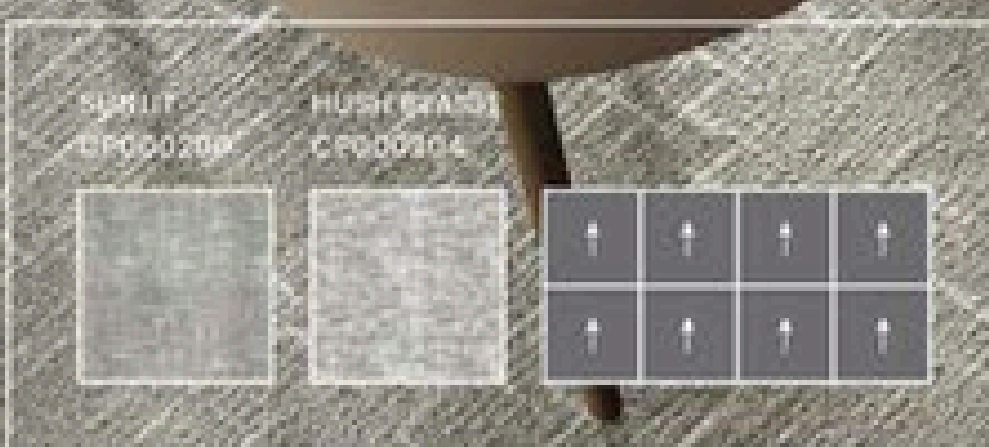

This image is used for illustration purpose only. The actual product appearance may vary.

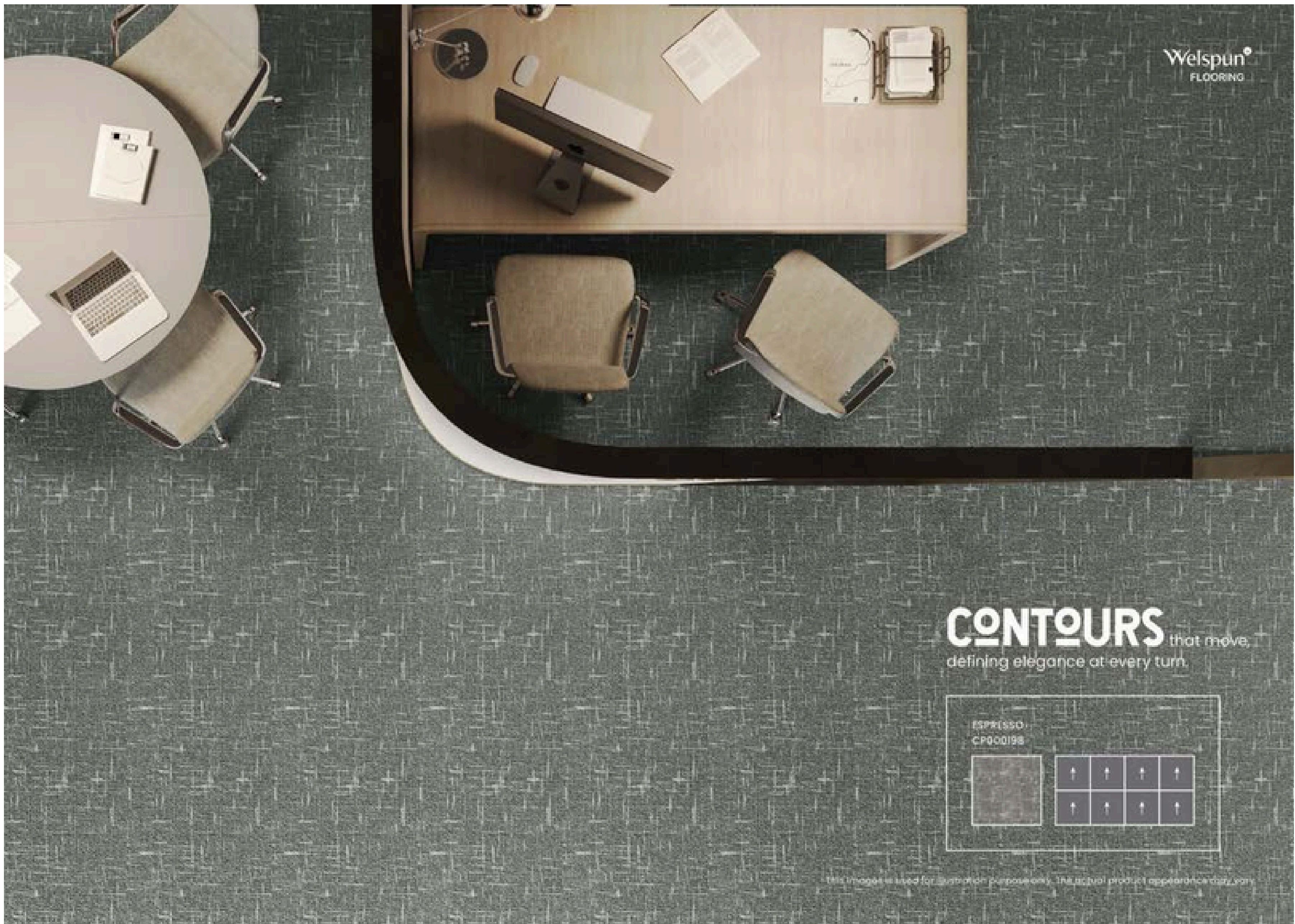



**DESIGNED** to intersect  
with every space, inspiring and elevating.

MANGOKARY CP000203	CLEAR GREY BEIGE CP000208	↑ ↑ ↑ ↑
		↑ ↑ ↑ ↑

The image is used for illustrative purposes only. The actual product appearance may vary.



**ARTISTRY** emerges  
where paths cross and dreams intertwine.

GOLDEN SANDSTONE BEIGE CP000205	↑ ↑ ↑ ↑
	↑ ↑ ↑ ↑

The image is used for illustrative purposes only. The actual product appearance may vary.



### FROM AN IDEA TO A REVOLUTION AND BEYOND

Welspun is one of India's fastest-growing global conglomerates. With, 'Har Ghar Welspun' at the heart of our culture, we are amongst global leaders in markets like U.S.A, Saudi Arabia, Europe and also India.

Welspun Flooring is Welspun Group's newest brainchild. With a state-of-the-art manufacturing facility spread over 300 acres, we are disrupting the world of flooring. Crafted passionately by our dedicated, team of experts, Welspun Flooring is a breakthrough in terms of engineering and design. With form meeting function in each style, you'll see flooring in a new light!

Product and Process Innovation is at the heart of everything we do here. We are proud that this drive to innovate has led to the creation of various trademarks, technologies and designs beyond category codes.

Our vertically integrated state-of-the-art manufacturing plant spread over 300 acres in Hyderabad, India is Asia's largest production facility and an epitome of advanced flooring technology.

With uncompromised notion, and with Welspun Flooring transcending boundaries, the same has carved a niche in the industry.

Welspun Flooring is winning the World, One room at a time.



### FEATURES

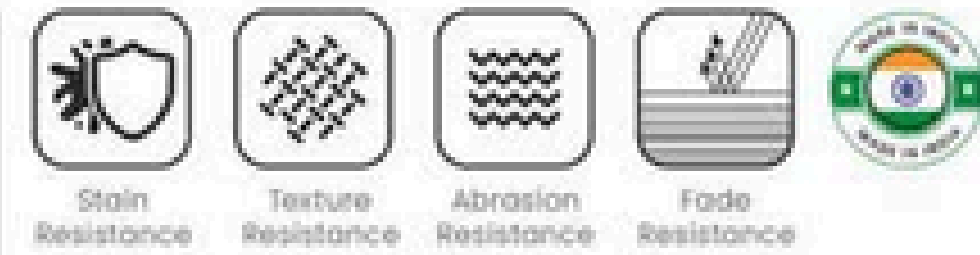

Also includes performance attributes of **HOME SHIELD**  
• Stain Resistance • Texture Resistance • Abrasion Resistance • Fade Resistance

### WARRANTIES

- Lifetime Stain Resistance Warranty
- Lifetime Fade Resistance Warranty
- 15 Year Limited Texture Resistance Warranty
- 15 Year Limited Abrasive Wear Warranty
- 15 Year Limited Pet Urine Stain & Odour Resistance Warranty

### PRODUCT SPECIFICATIONS

Machine Gauge	1/12 Rainbow loop infinity	Weight	814 gsm/24oz
Yarn	Nylon + pet	Density	5000+
Tile Size	61x61 cm	Backing	PVC + Cushion
Yarn Density	(1800x2) (1800x3)	Pile Thickness	6-7 mm
Pile Thickness	4 mm	Pile Height	(Nylon) (PET)
		Yarn	

### CERTIFICATIONS



### ALL FOR A BETTER TOMORROW !

A responsibility to the environment and a commitment to sustainable social progress have long been enshrined in Welspun's way of working. Be it the communities we influence, the families we're a part of or the entrepreneurs we partner with.

# CONNECTING

art and function to bring visions to life.

SYMPHONY  
CP000188



AZURE  
CP000183

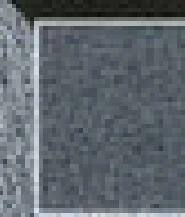

This image is used for illustration purpose only. The actual product appearance may vary.

# UNCOVER

the hidden artistry in the subtle interplay of shapes.

SAPPHIRE SERENITY  
CP000193

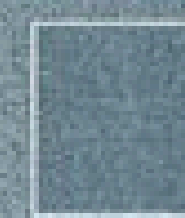

This image is used for illustration purpose only. The actual product appearance may vary.

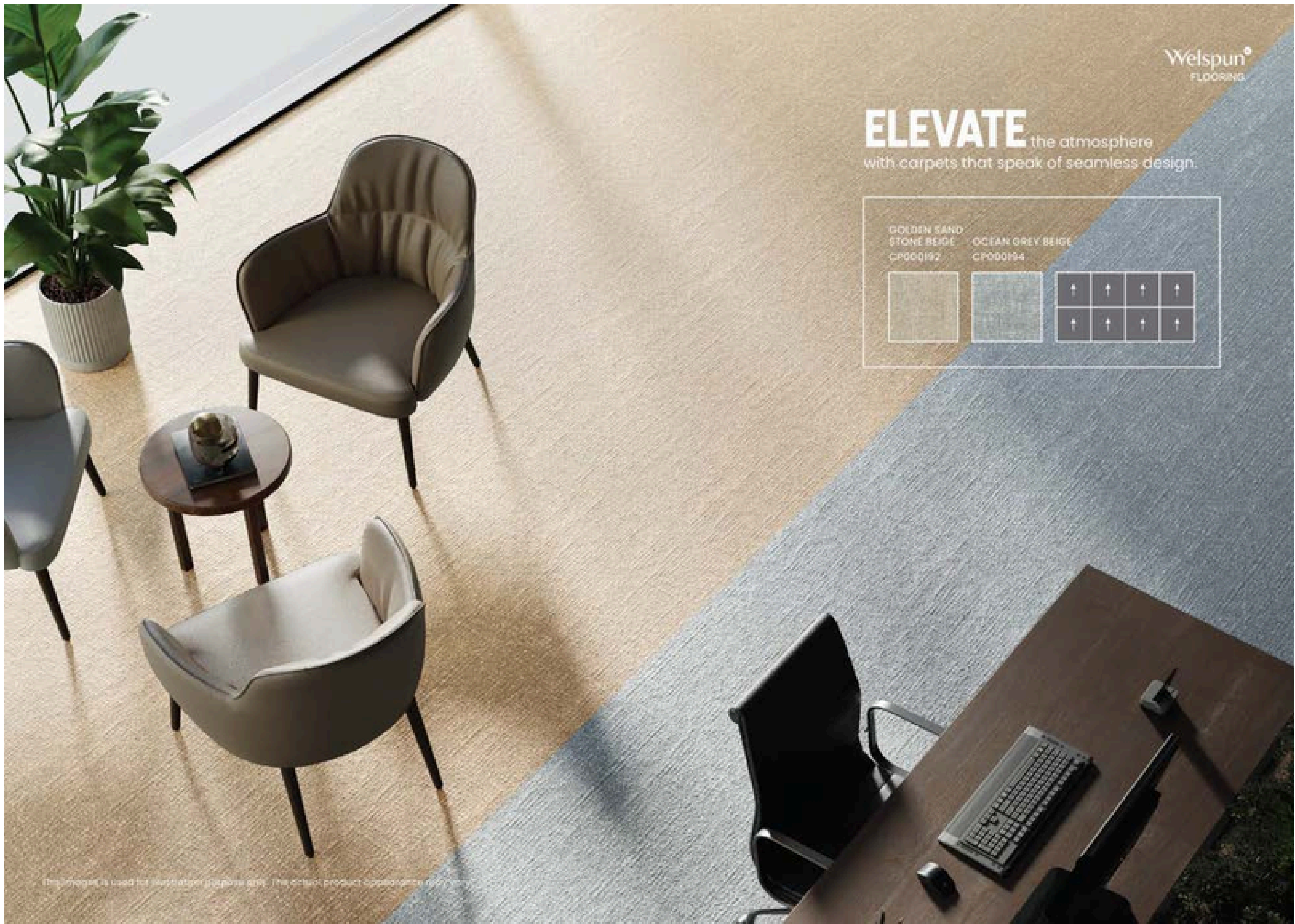

Welspun  
FLOORING

**ELEVATE** the atmosphere  
with carpets that speak of seamless design.

GOLDEN SAND STONE BEIGE CP000192	OCEAN GREY BEIGE CP000194	

This image is used for illustration purpose only. The actual product appearance may vary.



Welspun  
FLOORING

**PRECISION**

In design, bringing understated  
luxury to the forefront.

SUNLIT CP000186	

SAPPHIRE SERENITY CP000193	

This image is used for illustration purpose only. The actual product appearance may vary.

**DESIGN** meets comfort,  
creating a puzzle of plush sophistication.

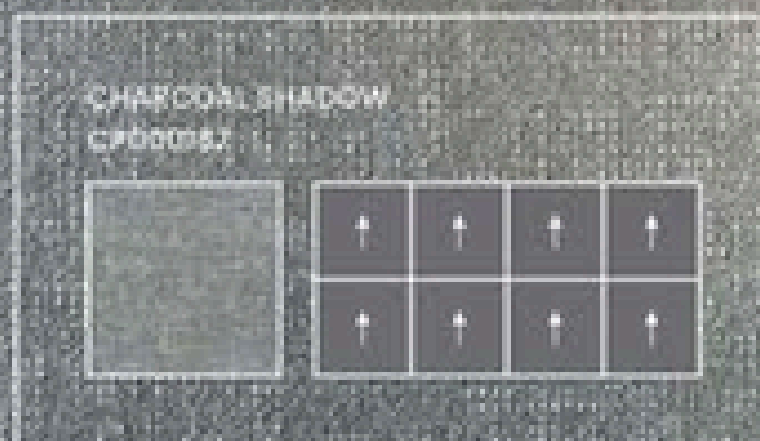

This image is used for illustrative purposes only. The actual product appearance may vary.

### FROM AN IDEA TO A REVOLUTION AND BEYOND

Welspun is one of India's fastest-growing global conglomerates. With, 'Har Ghar Welspun' at the heart of our culture, we are amongst global leaders in markets like U.S.A, Saudi Arabia, Europe and also India.

Welspun Flooring is Welspun Group's newest brainchild. With a state-of-the-art manufacturing facility spread over 300 acres, we are disrupting the world of flooring. Crafted passionately by our dedicated, team of experts, Welspun Flooring is a breakthrough in terms of engineering and design. With form meeting function in each style, you'll see flooring in a new light!

Product and Process Innovation is at the heart of everything we do here. We are proud that this drive to innovate has led to the creation of various trademarks, technologies and designs beyond category codes.

Our vertically integrated state-of-the-art manufacturing plant spread over 300 acres in Hyderabad, India is Asia's largest production facility and an epitome of advanced flooring technology.

With uncompromised nation, and with Welspun Flooring transcending boundaries, the same has carved a niche in the industry.

Welspun Flooring is winning the World. One room at a time.



### FEATURES



Stain Resistance

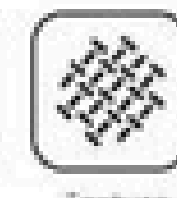

Texture Resistance

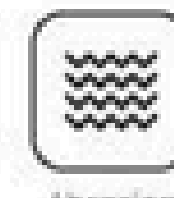

Abrasion Resistance

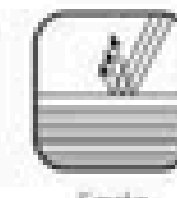

Fade Resistance



Also includes performance attributes of **HOME SHIELD**  
• Stain Resistance • Texture Resistance • Abrasion Resistance • Fade Resistance

### WARRANTIES

- Lifetime Stain Resistance Warranty
- Lifetime Fade Resistance Warranty
- 15 Year Limited Texture Resistance Warranty
- 15 Year Limited Abrasive Wear Warranty
- 15 Year Limited Pet Urine Stain & Odour Resistance Warranty

### PRODUCT SPECIFICATIONS

Machine Gauge	1/12 Rainbow loop infinity	Weight	814 gsm/24oz
Yarn	Nylon + pet	Density	5000+
Tile Size	61x61 cm	Backing	PVC + Cushion
Yarn Density	(1800x2) (1800x3)	Pile Thickness	6-7 mm
Pile Thickness	4 mm	Pile Height	(Nylon) (PET) Yarn

### CERTIFICATIONS



### ALL FOR A BETTER TOMORROW !

A responsibility to the environment and a commitment to sustainable social progress have long been enshrined in Welspun's way of working. Be it the communities we influence, the families we're a part of or the entrepreneurs we partner with,

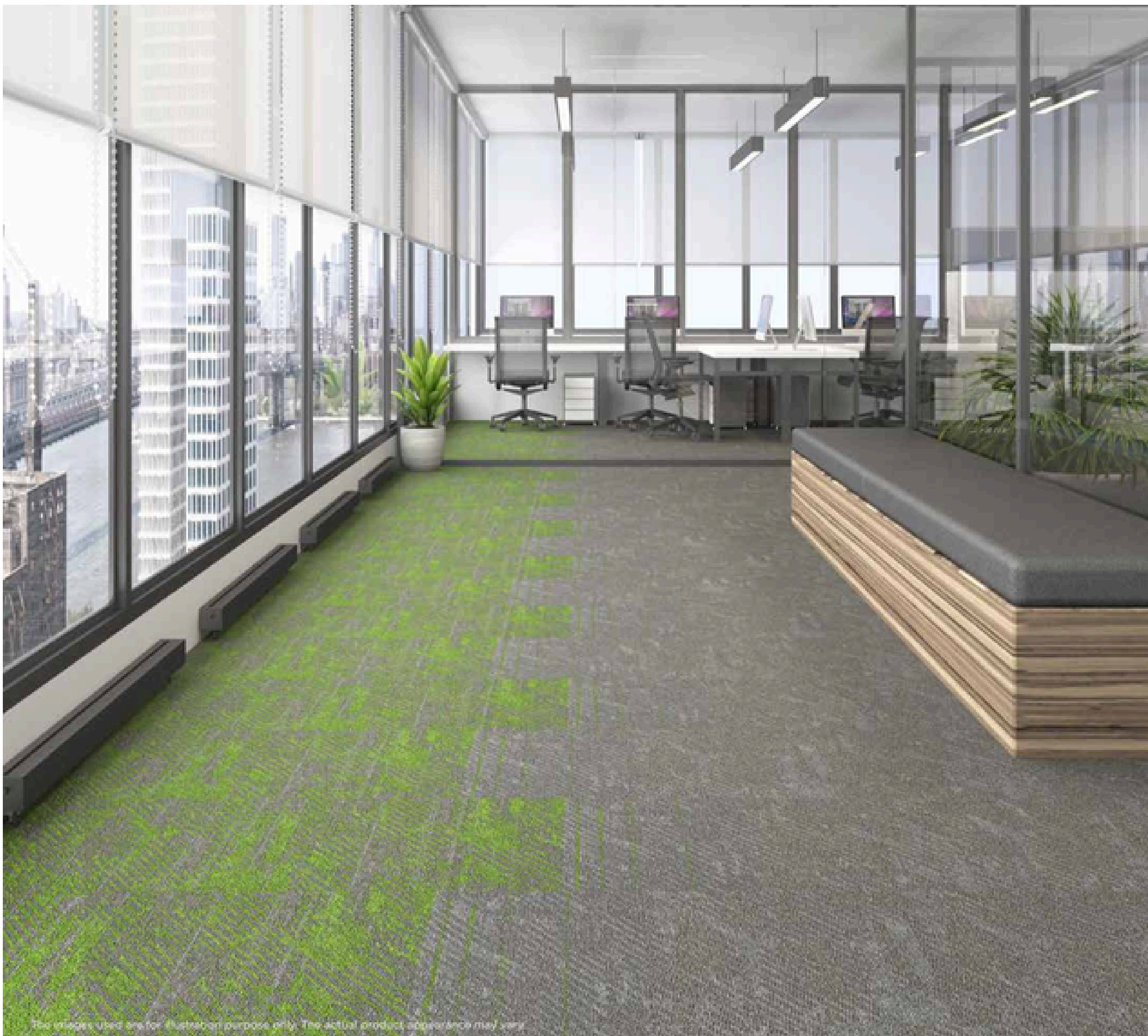

**GREEN ACCENT**  
CTY00208



**GREEN TRANSITION**  
CTY00214



**LIGHT GREY**  
CTY00203

MONOLITHIC

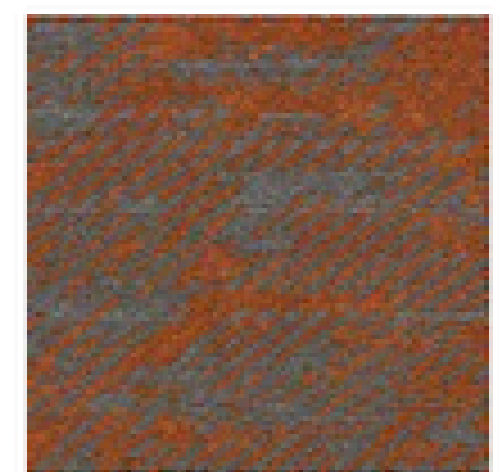
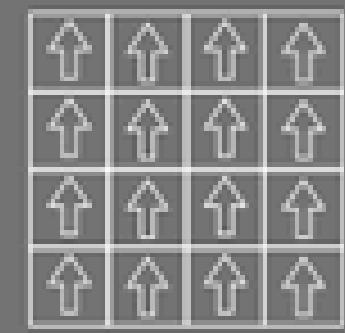

**PURPLE ACCENT**  
CTY00209

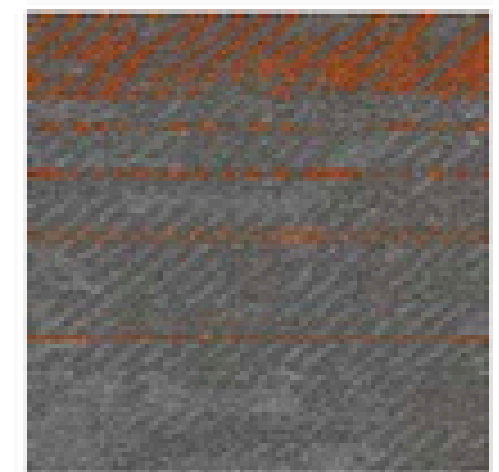

**PURPLE TRANSITION**  
CTY00215



**LIGHT GREY**  
CTY00203

MONOLITHIC

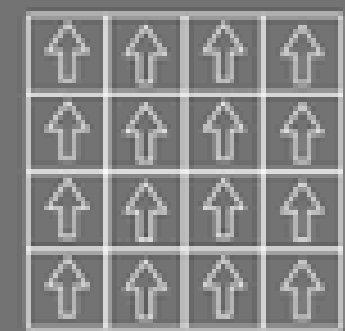

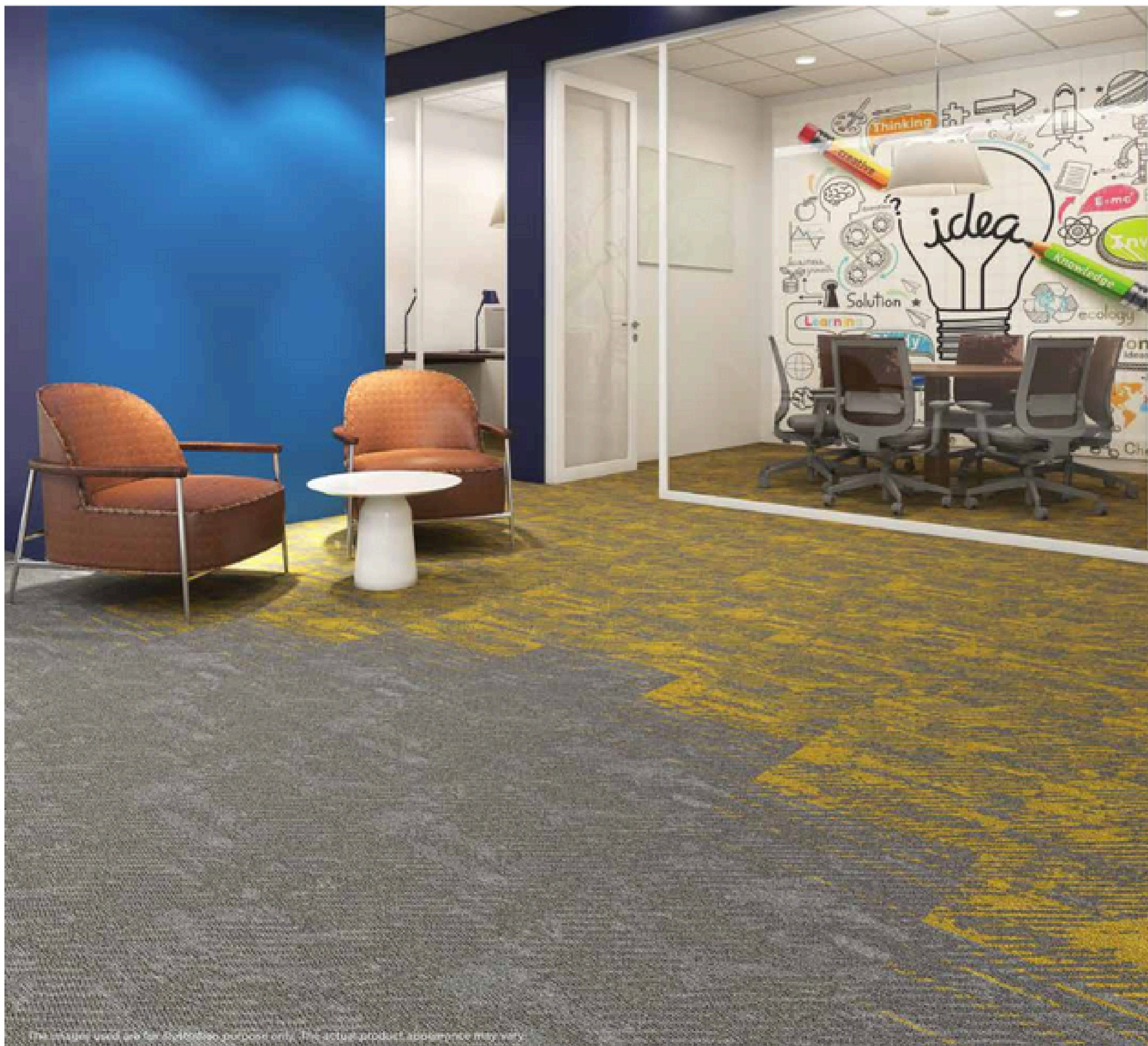

The images used are for illustration purposes only. The actual product appearance may vary.

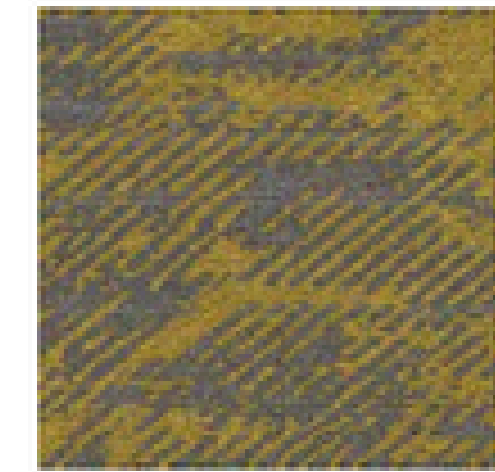

**YELLOW ACCENT**  
CTY00210

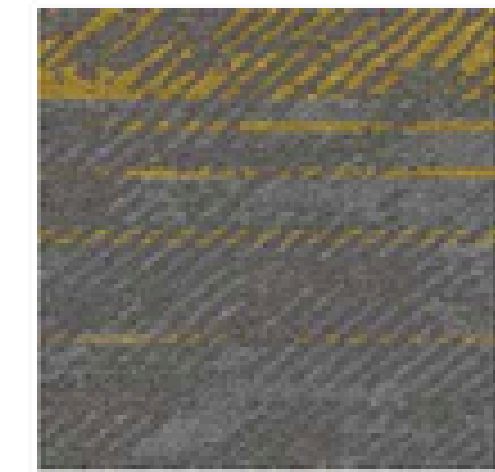

**YELLOW TRANSITION**  
CTY00216



**LIGHT GREY**  
CTY00203

ASHLAR

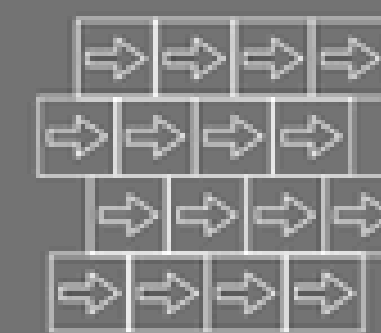

**Welspun**  
FLOORING

**PRODUCT SPECIFICATION**

Collection Name	Meander
Machine Gauge	1/10 loop infinity
Yarn	PET
Size (CM)	50x50
Pile Height	3.0-3.2 mm
Total Thickness	5.0-5.5 mm
Density	4000
SPI	10.3
Tufting Weight (Oz)	475/14 oz
Backing System	Welspun Ecolite or Comfortile
Indicates	+/-5%

**TEST REPORT SUMMARY**

Test Name	Method	Test Name	Method
Delamination	ASTM D 3956	Static Electricity	AATCC 134-1996
Tuft Bind	ASTM 1335-67	Anti Static	ANSI/ESD S 7.1
Dimensional stability	ASTM D 7570	Castor Chair	DIN 54124
Pile weight	ASTM D 5848-07	Hexapod	ASTM D 5252-15
Pile density	ASTM D 5848-07	Static Coefficient	ASTM C 1028
Total thickness	ASTM D 6988-08	Dimensional stability (Aachen test)	DIN-STD-5438/ITTS-004
Pile height	ASTM D 5823-05a	Anti Soil	ASTM D 6540-05
Gauge	ASTM D 5793-13	Shampoo Fastness	AATCC 136
Tuft density	ASTM D 5848	Water Fastness	AATCC 107
Flammability (Pill Test)	ASTM D 2859	Velcro-Loops	ITTS 112
Flammability (Radiant Panel)	ASTM E 648-06	Heavy Traffic test (Walk test)	ASTM 6119-03
NBS Smoke Density (Flaming)	ASTM E 662-06	Sound transmission	ASTM C 423-17
Lightfastness	AATCC 16 E	Sound Absorption	ASTM C 423-17
Colour fastness to Ozone	AATCC 129	Static Loading	ISO 065/3415
Colour fastness to NO <sub>2</sub>	AATCC 164-2008	Green Carpet (VOC)	ASTM D 5196
Crocking Dry and Wet	AATCC 165-2008	Acoustic	BS EN ISO 354
Stain fastness	AATCC 175-2008/ITTS 002	Thermal Resistance	ASTM C 518

**CARPET TILES ADVANTAGES**



**TRADEMARKS & TECHNOLOGIES**

- Welspun Ecolite™**  
Welspun Ecolite™ backing are made up of lightweight PVC that not only reduces the overall weight significantly but ensures a 40% lower environmental footprint than traditional carpets. Despite that, this backing retains the highest performance standards.
- Now also available with **Healthy Floor™** (Optional).  
We also have carpet tile options with antiviral properties. Tested and certified by ResInnova Labs, we are India's first antiviral carpet tiles. It kills 99.68% of human coronavirus due to a special coating of silver iron & titanium oxide. We make healthy floors.
- Comfortile™** (Optional).  
With Comfortile™ backing, our tiles come with a customized felt-back that not only offers great underfoot comfort but also sound absorption. Comfortile™ provides extra levels of protection and support for high levels of acoustic and ergonomic comfort.

**CERTIFICATION**



## Wel-Lock Technology

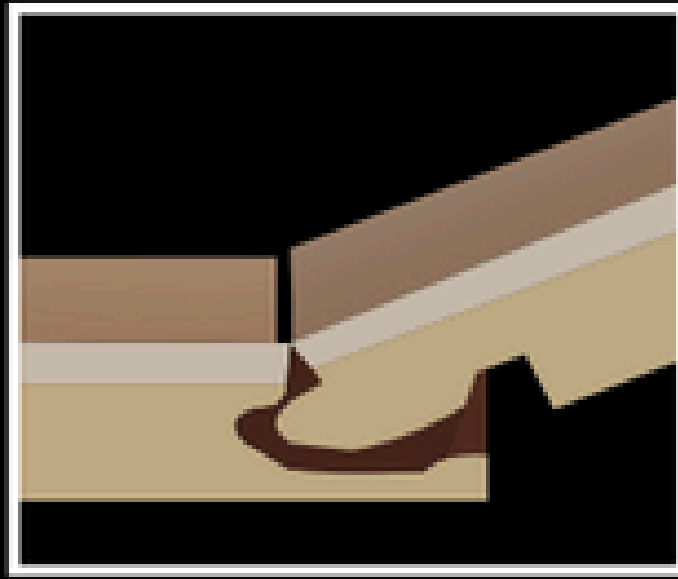

Welspun Click N Lock Tiles® has an innovative locking system for an easy and fast floating installation method. A floating installation saves you labor and material costs, eliminating adhesive, solvent and cleaning; it also cuts down on installation time and allows you to walk on your floor immediately after work completion.

Floating Installation for Welspun Click N Lock Tiles® can be done over most existing sub-floors - vitrified tiles, ceramic tiles, natural stone and epoxy\*. Welspun Click N Lock Tiles® uses an angled locking system which is a strong and robust, mechanical and glue-free.



## Structure

**Click N Lock Tiles®** is an upgrade and improvement of Luxury Vinyl Tiles Flooring. The main contents of Click N Lock Tiles® Flooring Core are polyvinyl chloride, natural limestone powder and stabilizers. Click N Lock Tiles® flooring combines the strength of stone and the beauty of wood with four layers designed to resist wear and retain a luxurious look for decades.

Click N Lock Tiles® Flooring features include dimensional stability, waterproofness, indentation resistance against high density core. It can be installed on different types of floor bases - concrete, epoxy, ceramic, or existing flooring.

Its formaldehyde free, and is suitable for residential and commercial applications.

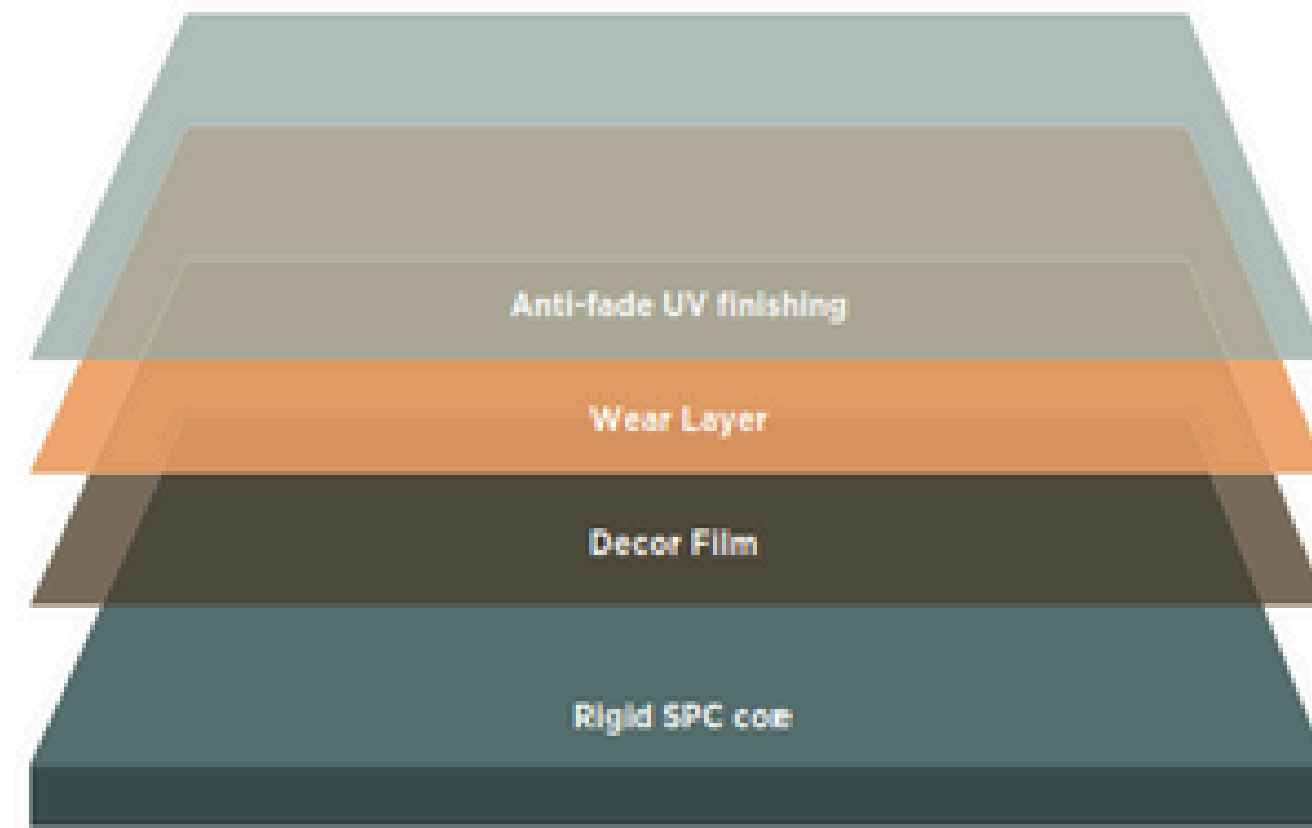

5

## Why Click N Lock Tiles®?



## Welspun Advantages

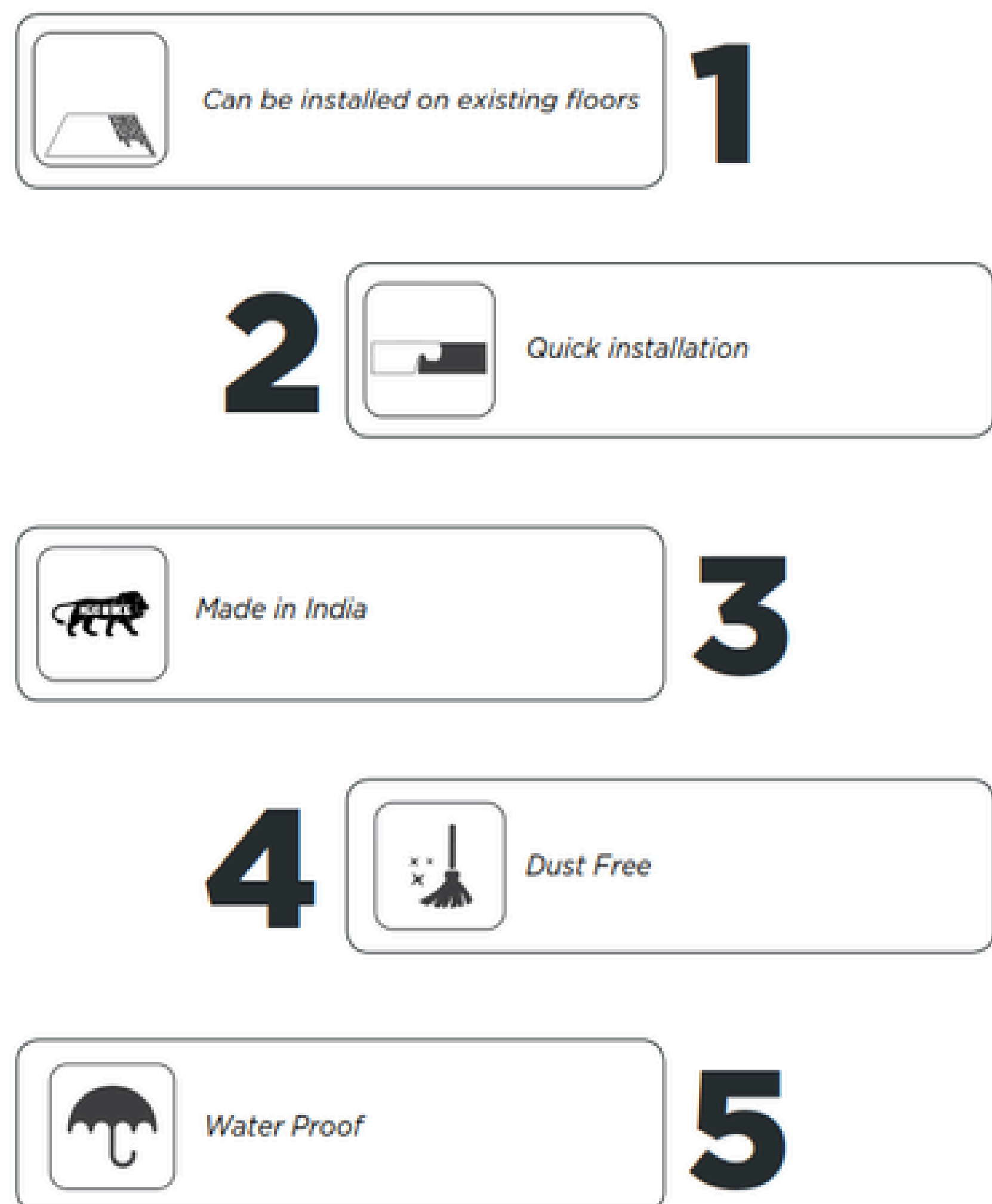

# Welspun WPC Accessories

Seamless Finish for your Click N Lock Tiles® Flooring

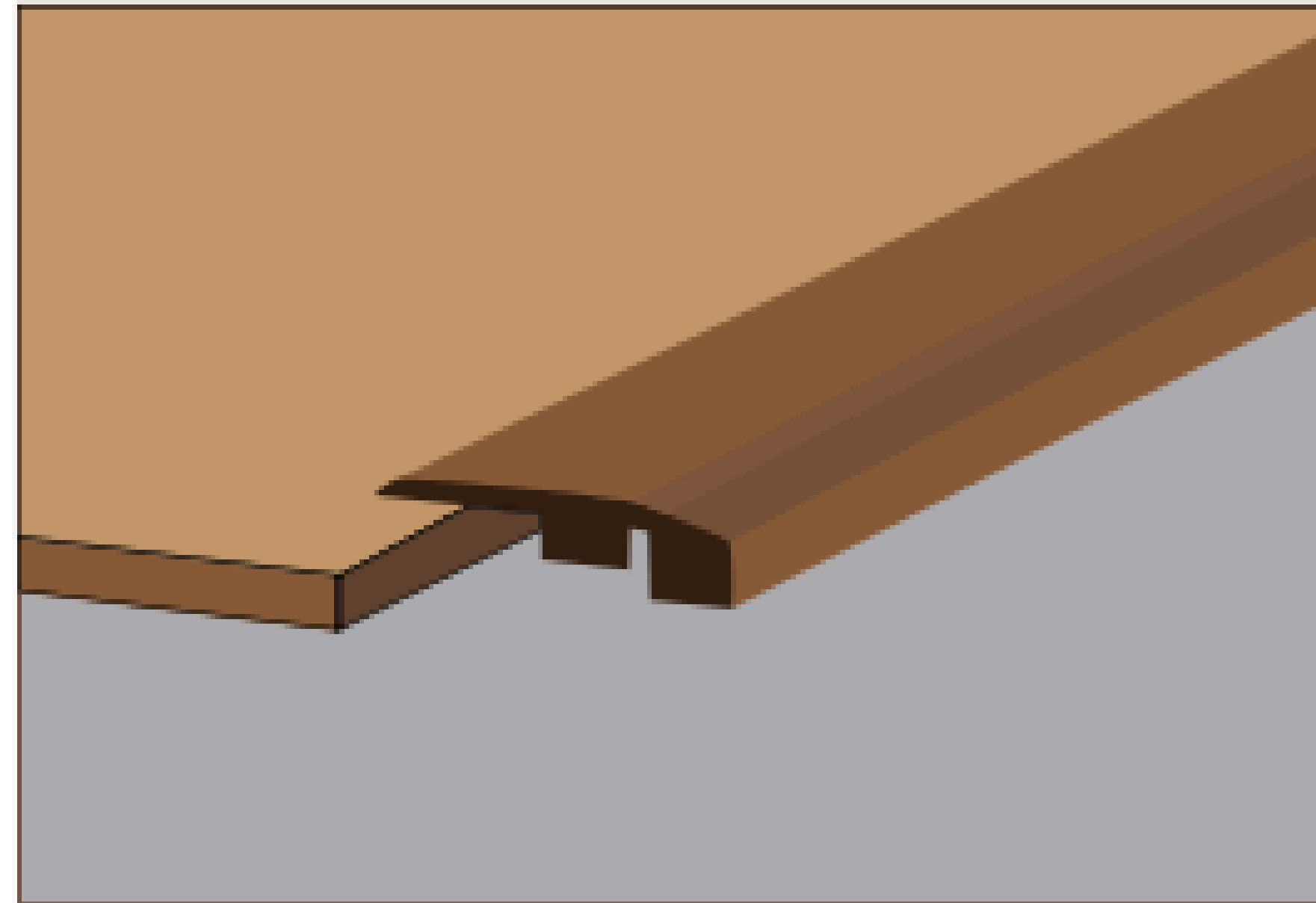

The accessories are designed to match your floor. The core of the accessories is made of WPC (Wood Plastic Composite), the top décor film of which is a duplicate of your floor.

## T Moulding

From Click N Lock Tiles® to Any

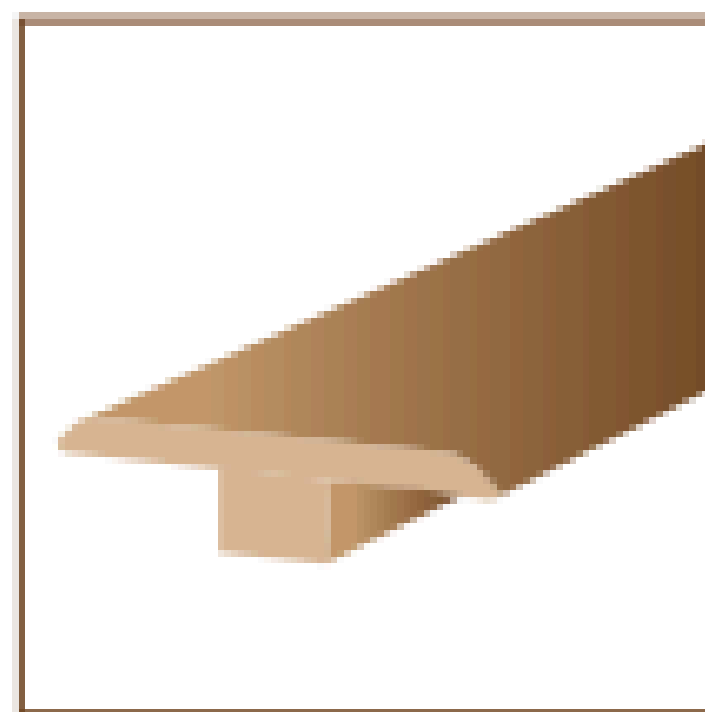

## Reducer

From Click N Lock Tiles® to Base Floor

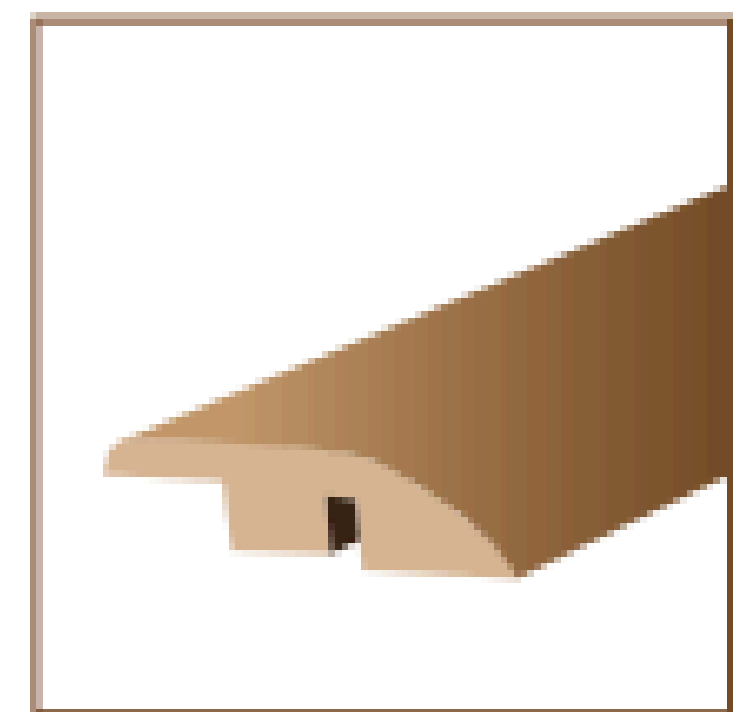

## Skirting

Finishing the edges of the floor to wall

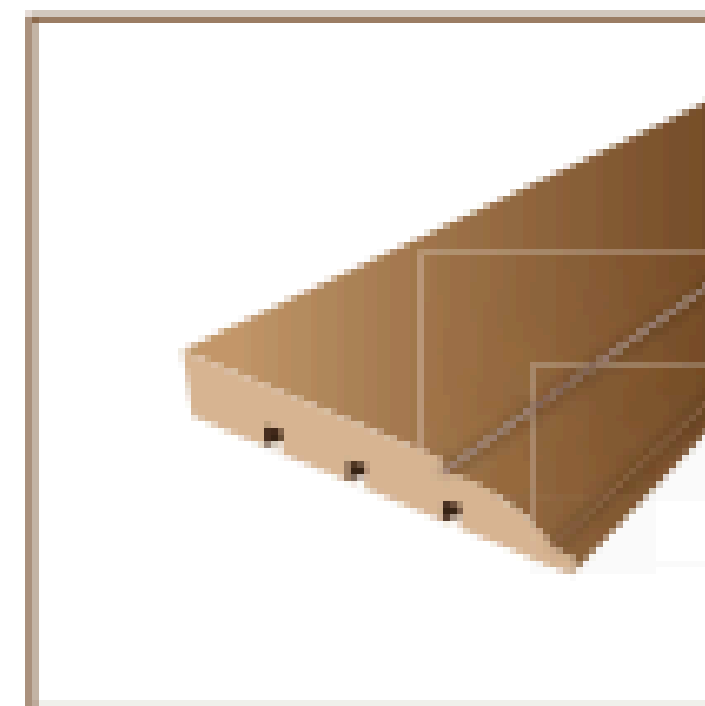

## Quarter Round

Finishing the edges of the floor to wall

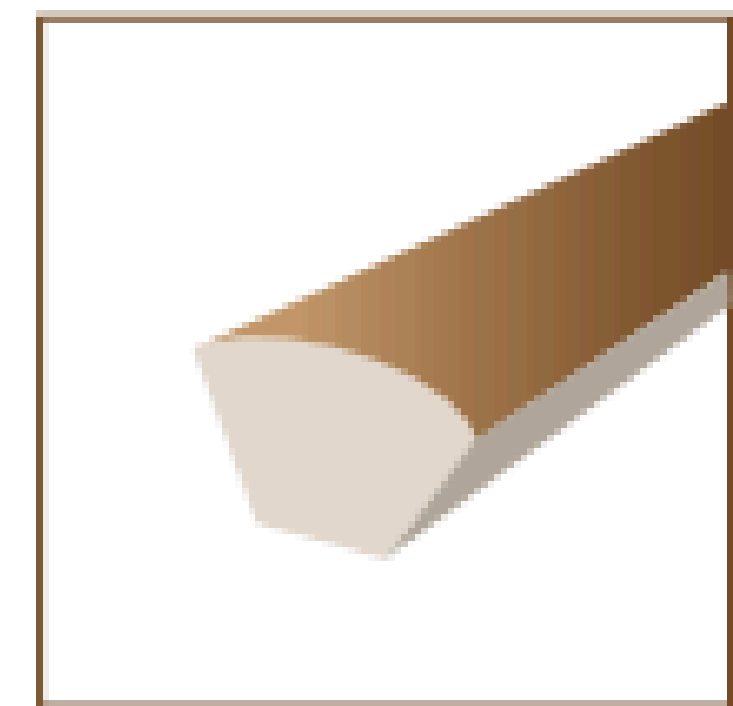



Article code: 1039376  
Design: Harvest Brown  
No. of tiles/box: 10



Article code: 10393896  
Design: Bone Brown  
No. of tiles/box : 14



Article code: 1039373  
Design: Bone Brown  
No. of tiles/box : 10



Article code: 1039367  
Design: Platina White  
No. of tiles/box : 17



Article code: 1039121  
Design: Platina White  
No. of tiles/box : 9



Article code: 1039123  
Design: Antique Brown  
No. of tiles/box : 9

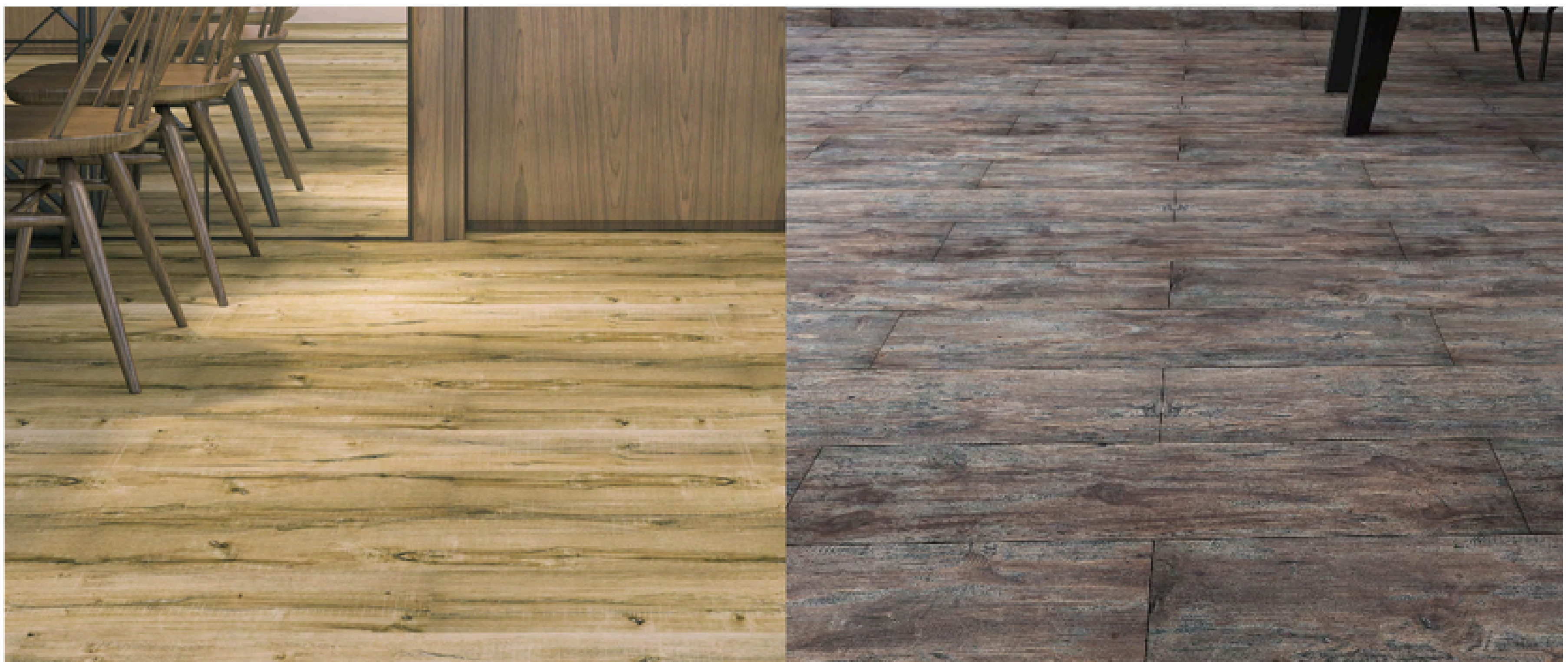



Article code: 1039117  
Design: Light Camel  
No. of tiles/box : 10

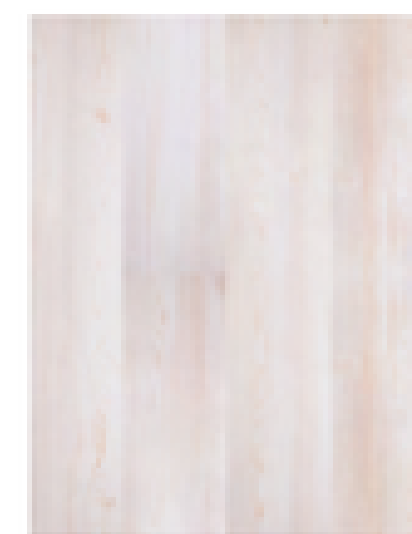

Article code: 1039118  
Design: Misty Pine  
No. of tiles/box : 9

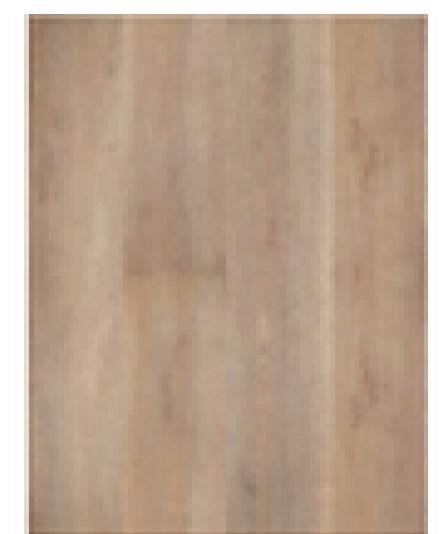

Article code: 1039119  
Design: Light Oak  
No. of tiles/box : 9

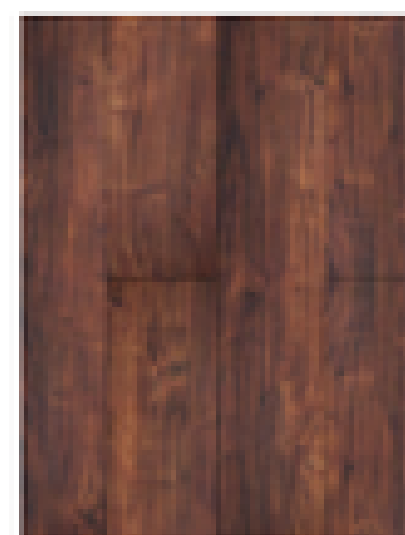

Article code: 1039129  
Design: Red Robinia  
No. of tiles/box : 9

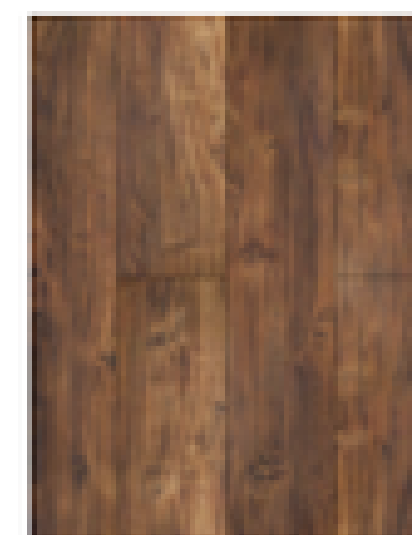

Article code: 1039130  
Design: Spice Robinia  
No. of tiles/box : 9



Article code: 1039126  
Design: Raw Umber  
No. of tiles/box : 9



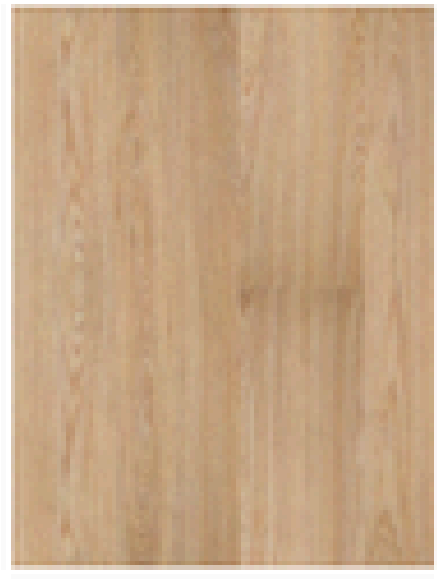

Article code: 1039356  
Design: Oak Buff  
No. of tiles/box : 18

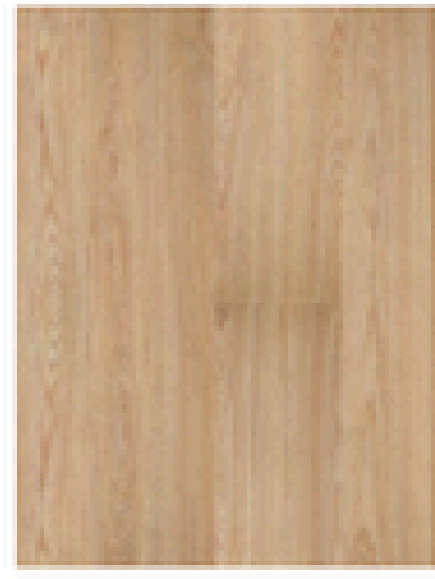

Article code: 1039087  
Design: Oak Buff  
No. of tiles/box : 10

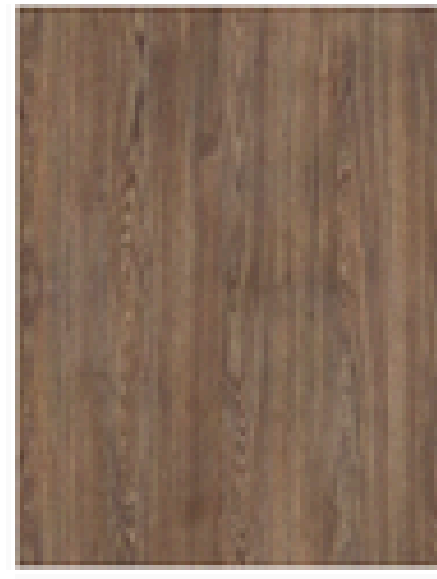

Article code: 1039357  
Design: Mid Oak  
No. of tiles/box : 18



Article code: 1039368  
Design: Golden Sand  
No. of tiles/box : 17

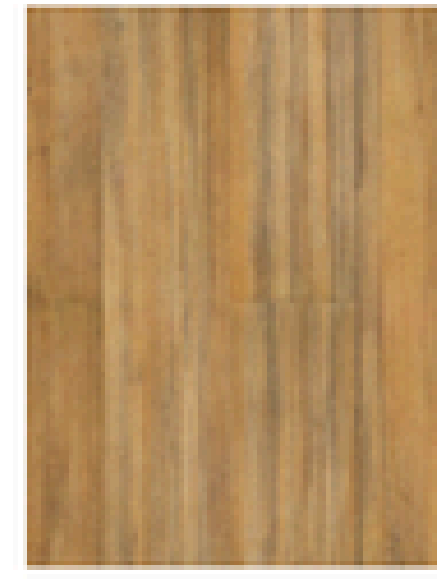

Article code: 1039374  
Design: Golden Sand  
No. of tiles/box : 9

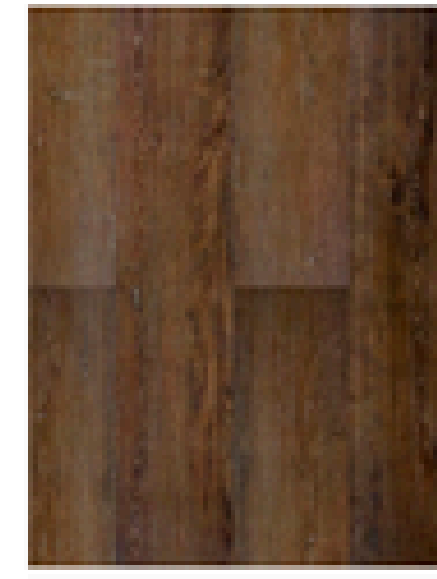

Article code: 1039375  
Design: Imperial Sand  
No. of tiles/box : 10

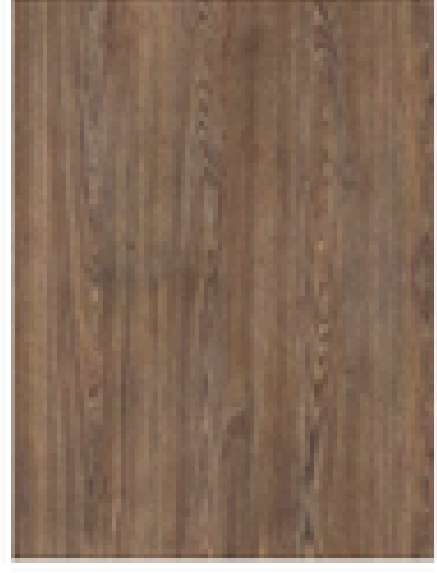

Article code: 1039089  
Design: Mid Oak  
No. of tiles/box : 10

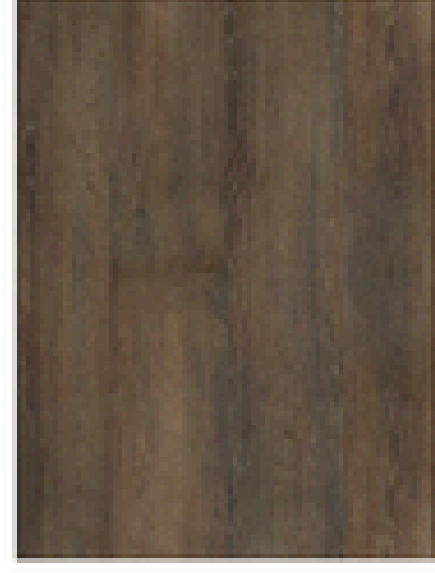

Article code: 1039358  
Design: Ginger Brown  
No. of tiles/box : 18

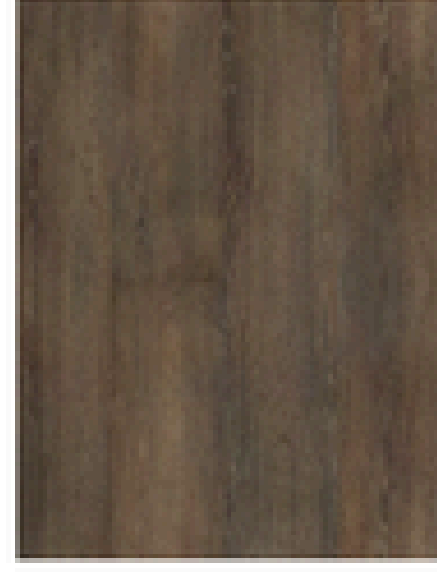

Article code: 1039091  
Design: Ginger Brown  
No. of tiles/box : 10



Article code: 1039369  
Design: Mud Brown  
No. of tiles/box : 17



Article code: 1039355  
Design: Desert Sand  
No. of tiles/box : 18

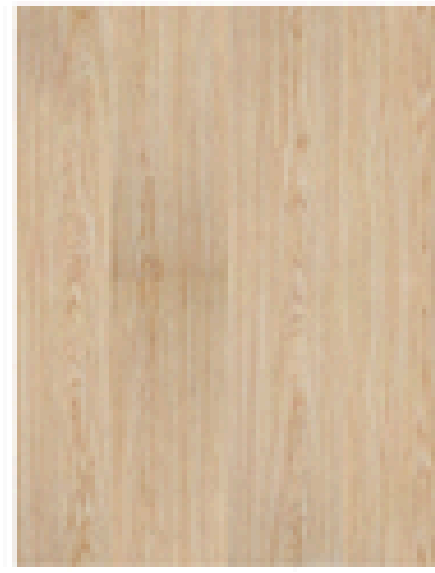

Article code: 1039085  
Design: Desert Sand  
No. of tiles/box : 10



Article code: 1039365  
Design: Natural Beige  
No. of tiles/box : 18

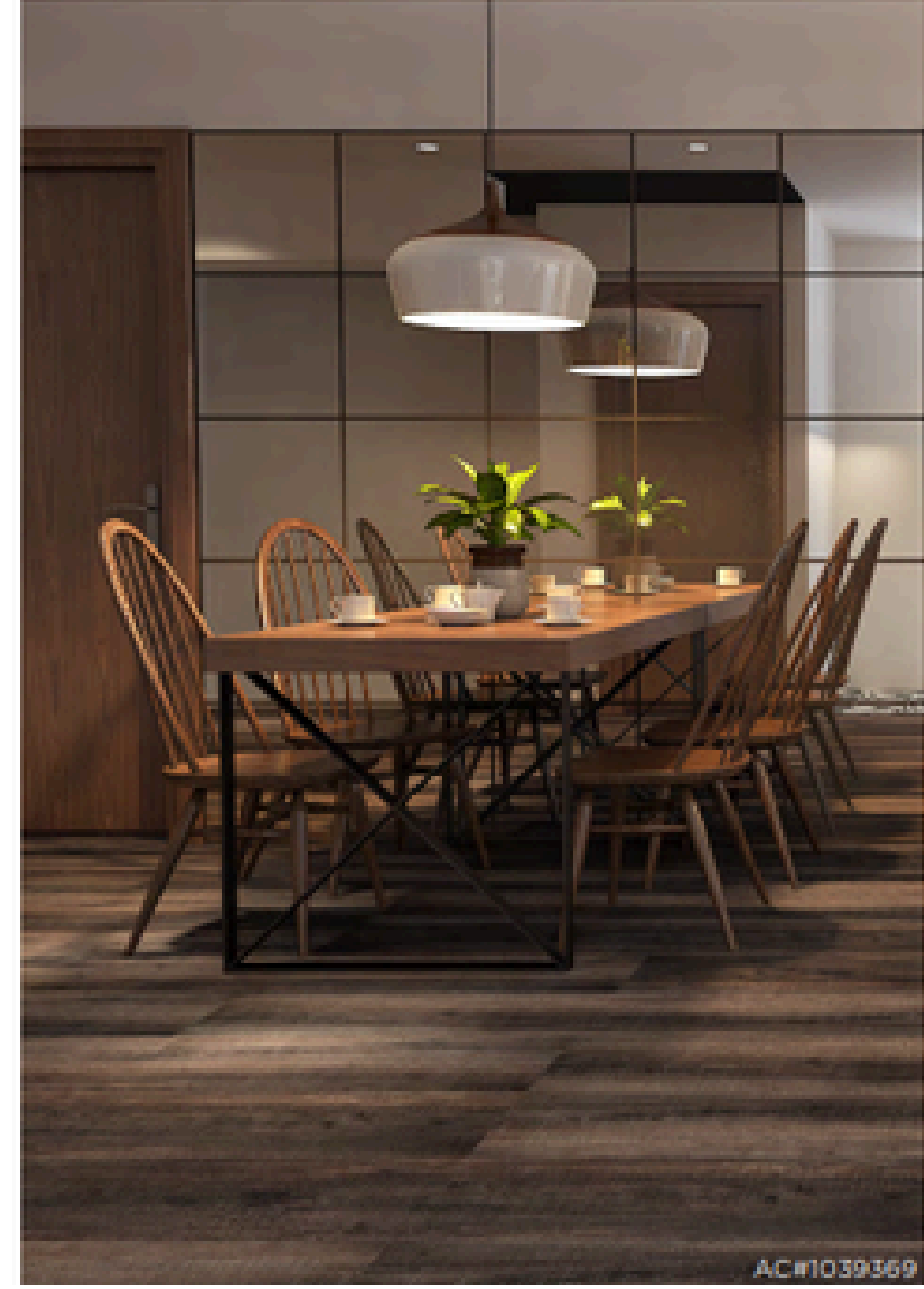

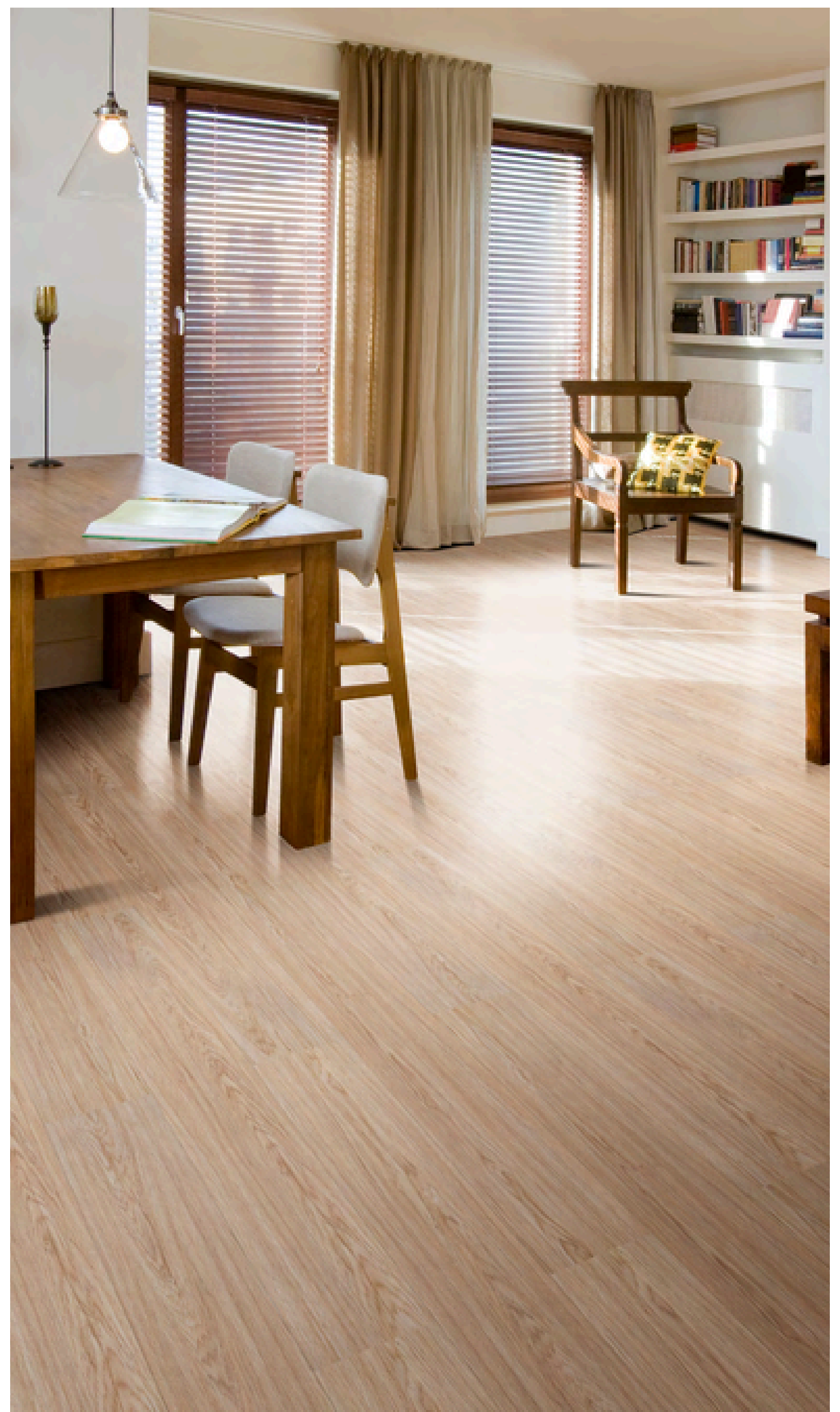







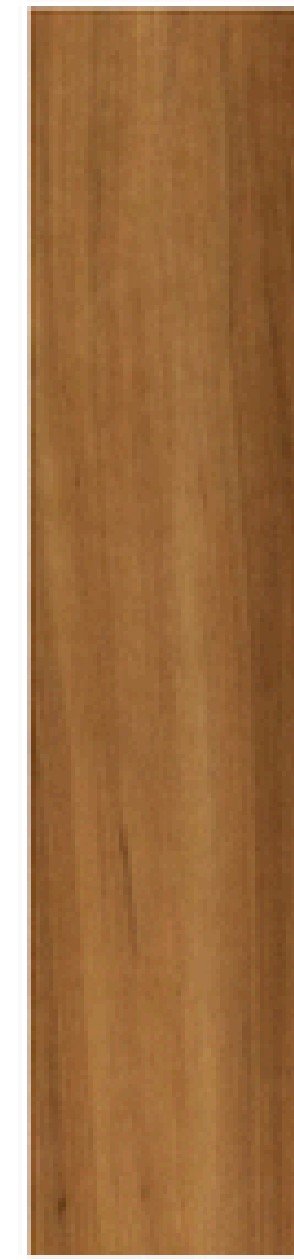

Artile Code# 1042195  
Design: Amber beige  
Size: 6x36 inches  
Material: Wood  
Click System: Reverse

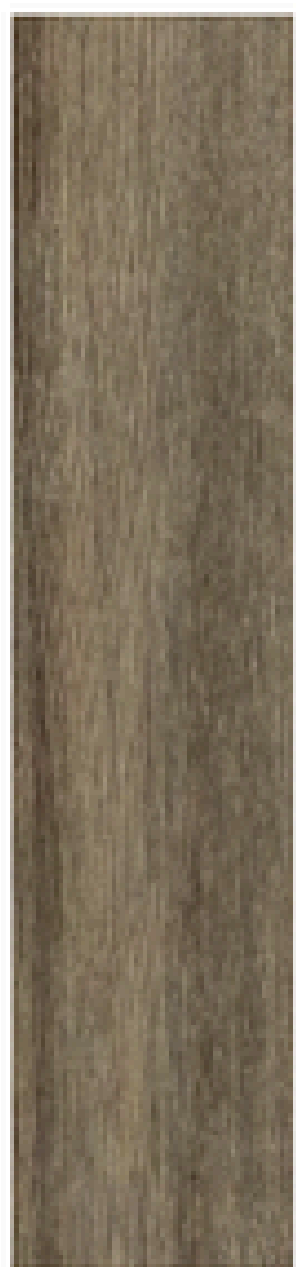
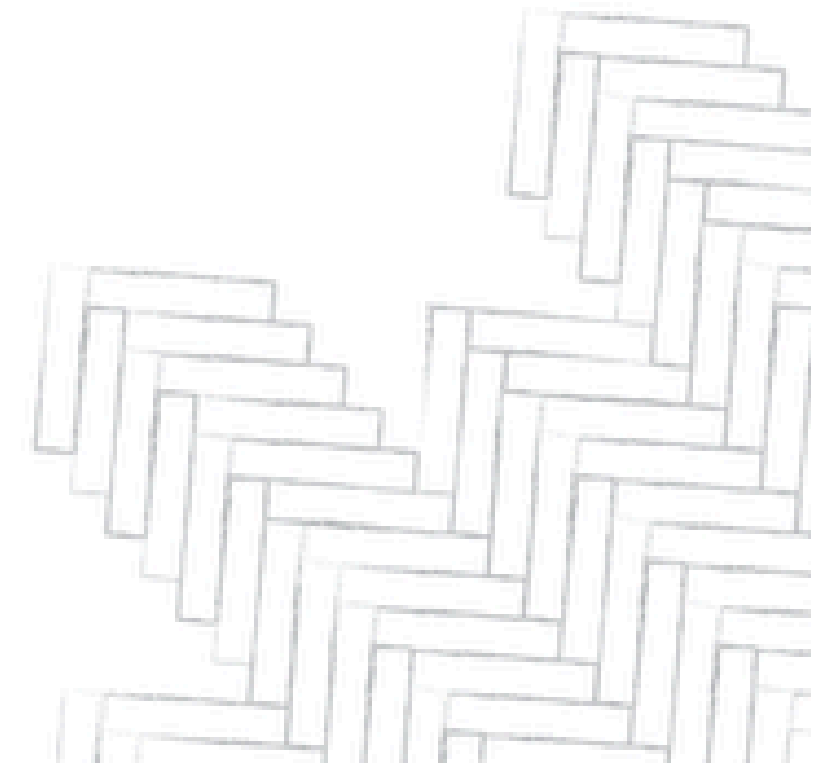

Artile Code# 1042196  
Design: Brownstone  
Size: 6x36  
Material: Wood  
Click System: Reverse

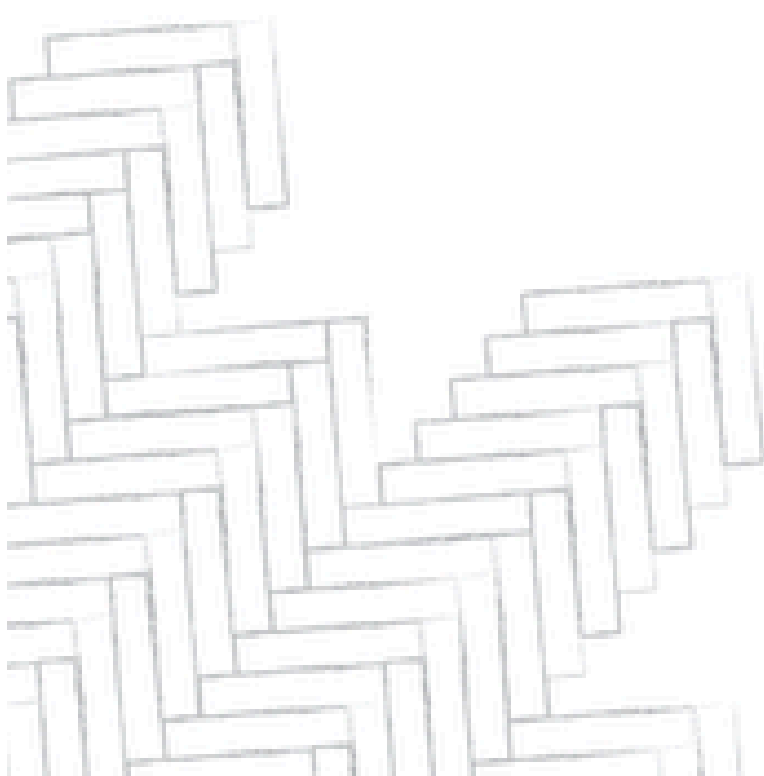

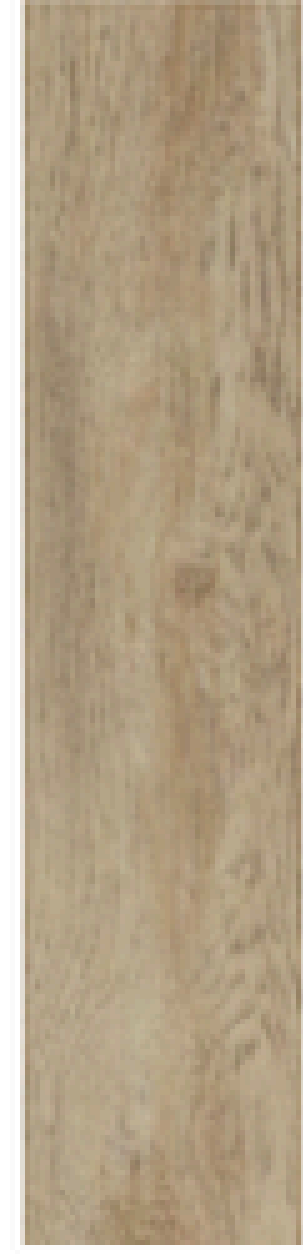

Artile Code# 1042199  
Design: Acorn yellow  
Size: 6x36 inches  
Material: Wood  
Click System: Reverse

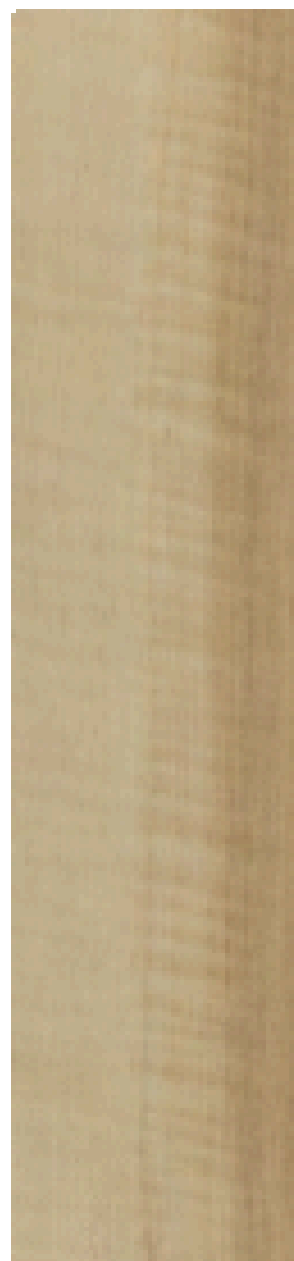
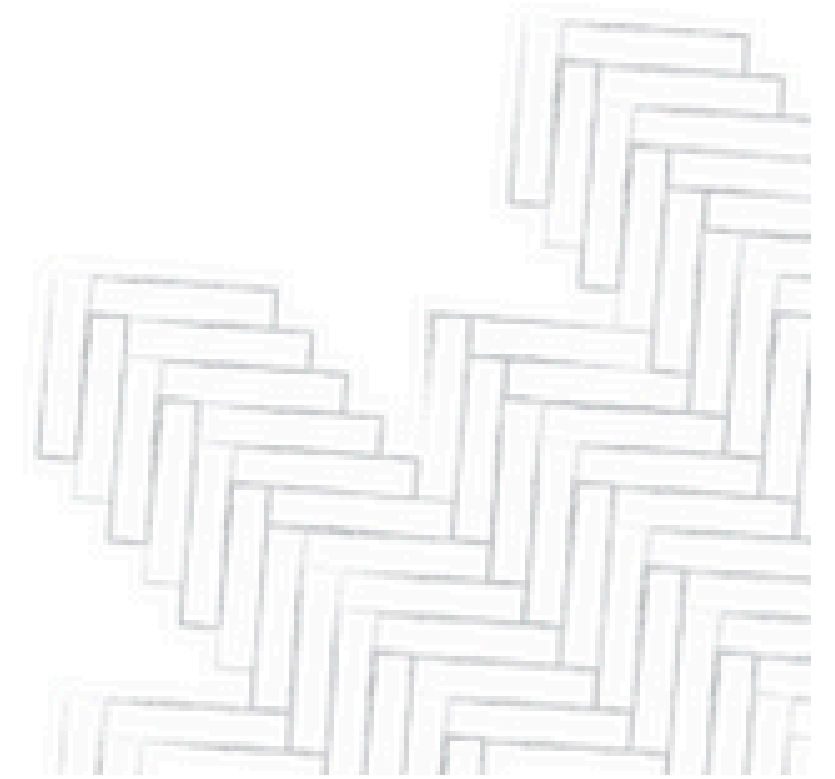

Artile Code# 1042198  
Design: New gold  
Size: 6x36 inches  
Material: Wood  
Click System: Reverse

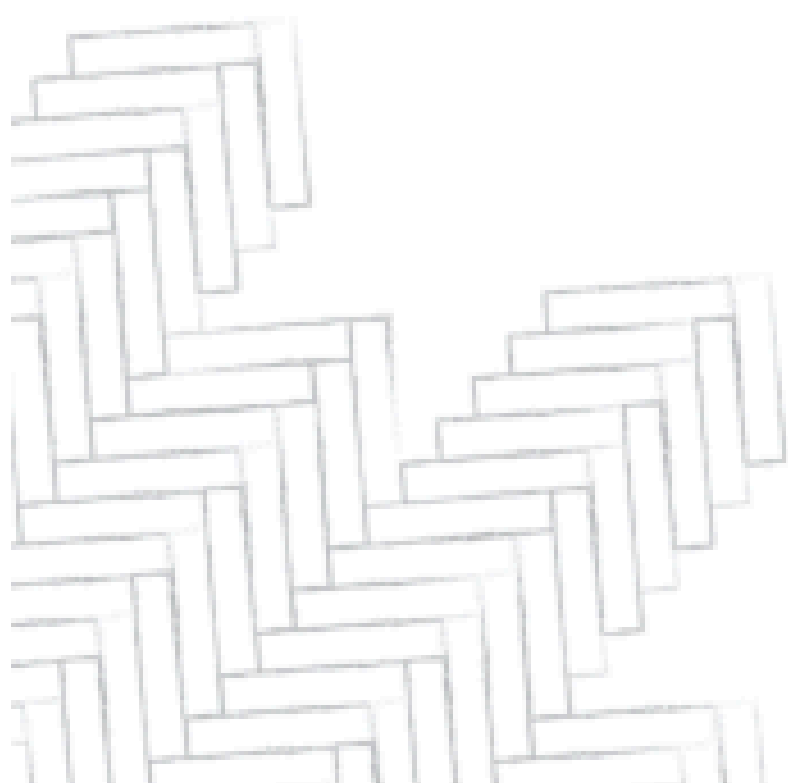

# SEGMENTS



AGED CARE

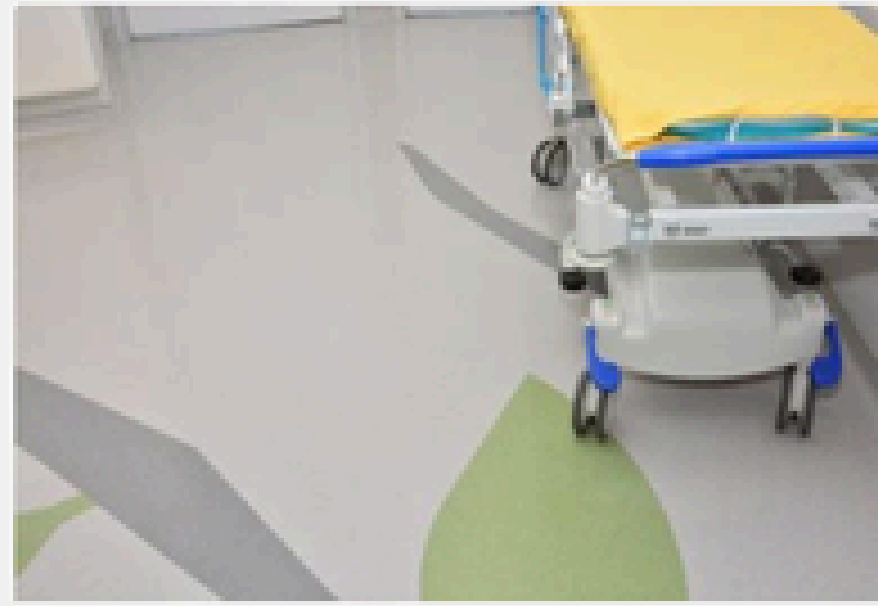

HEALTH CARE



EDUCATION

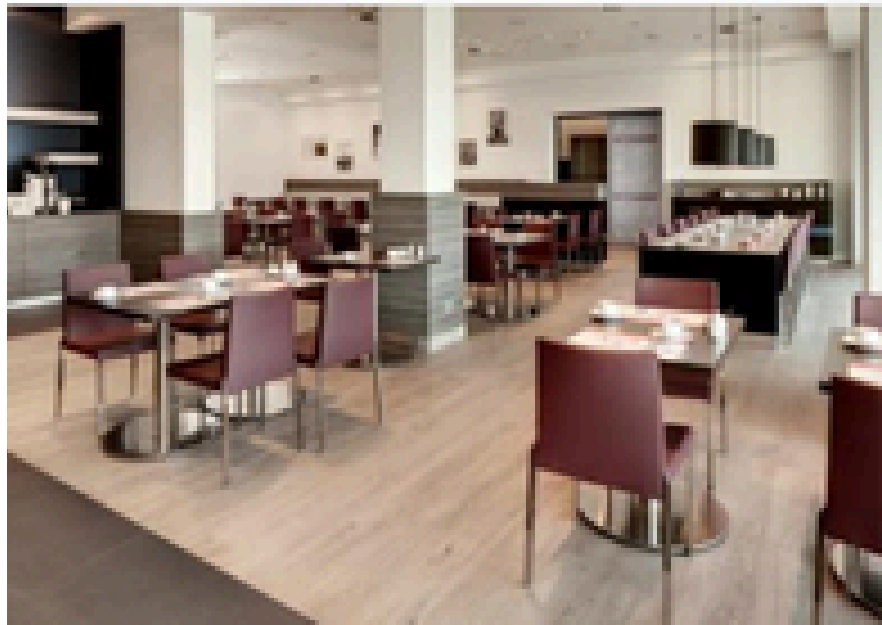

HOSPITALITY



OFFICES

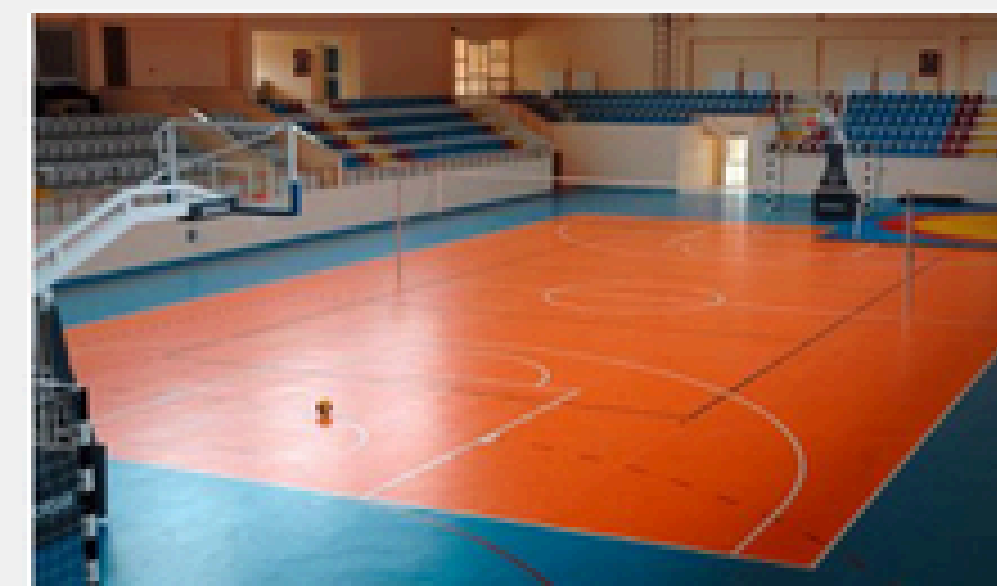

INDOOR SPORTS

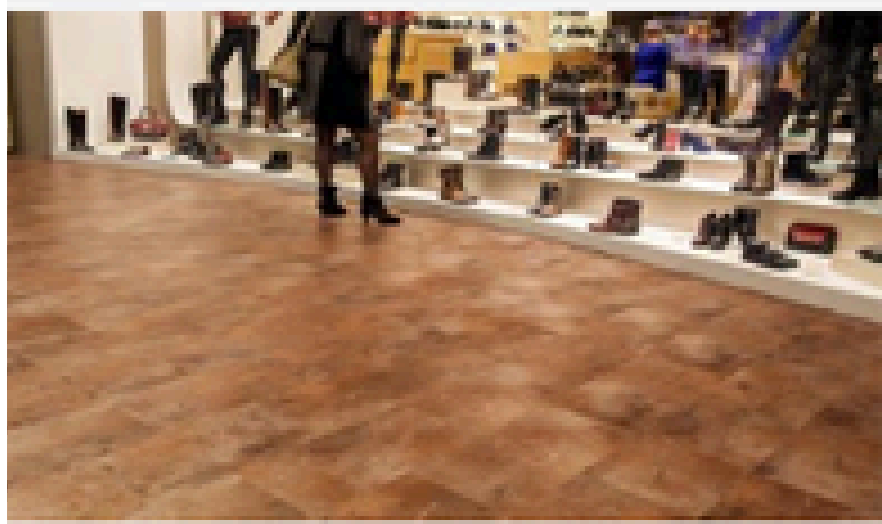

RETAIL

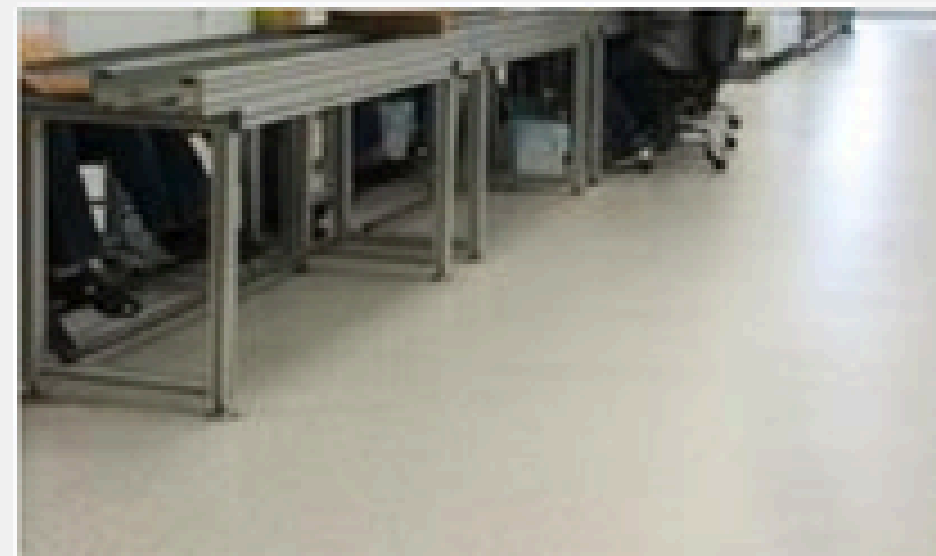

STORAGE &  
TRANSPORTATION

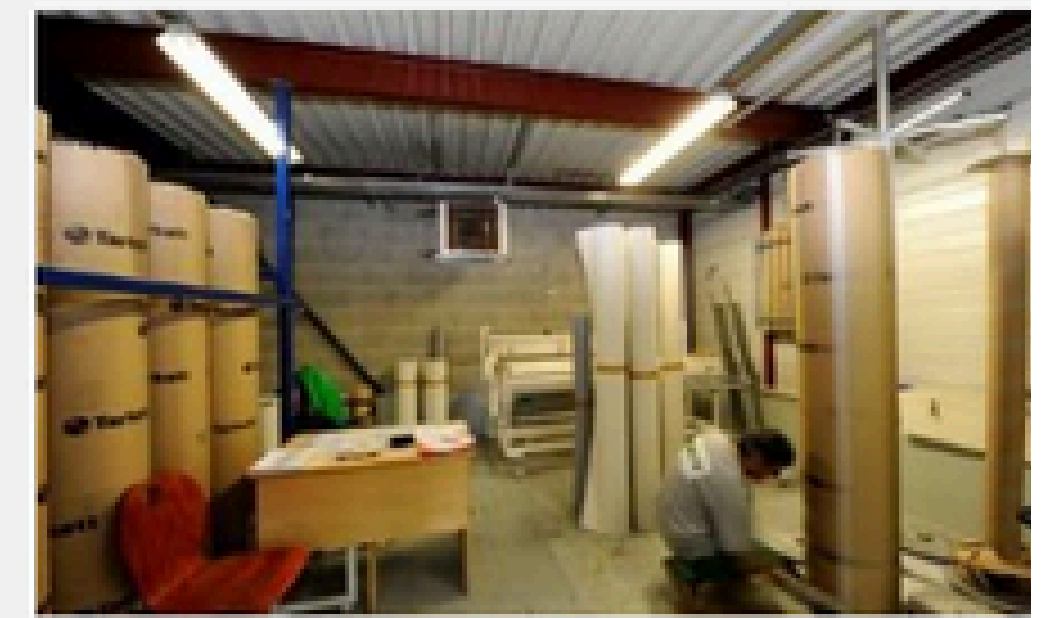

HOUSING

# WOODEN / RUBBER FLOORING

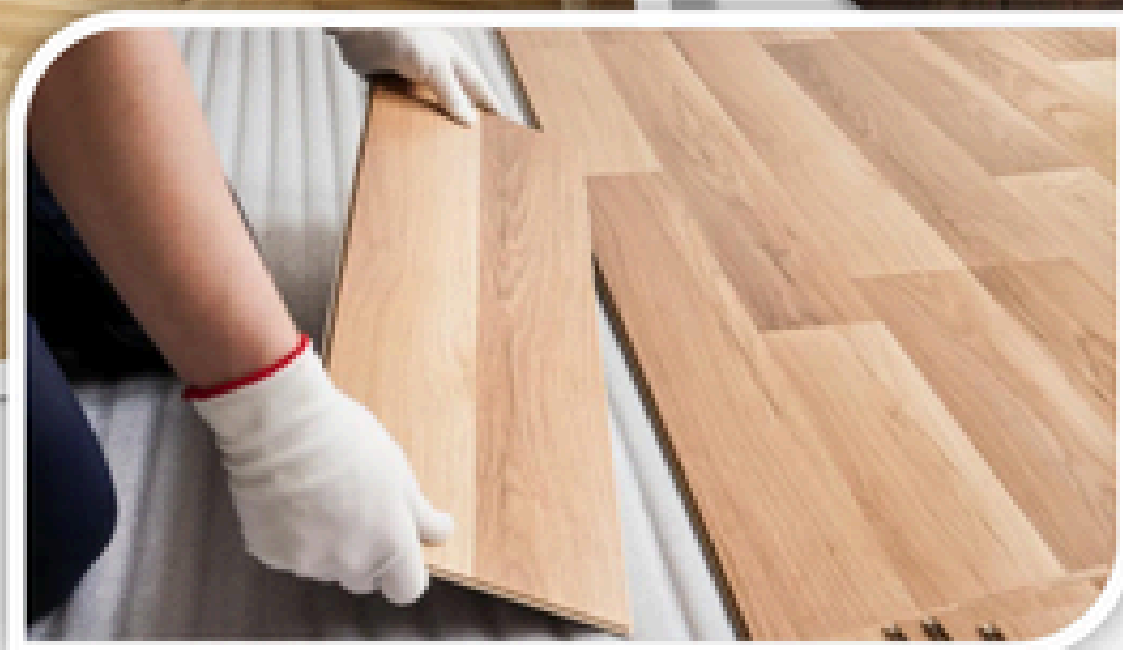

# RAISED ACCESS FLOORING

raised access floor systems of high quality and competitiveness in the different world markets.

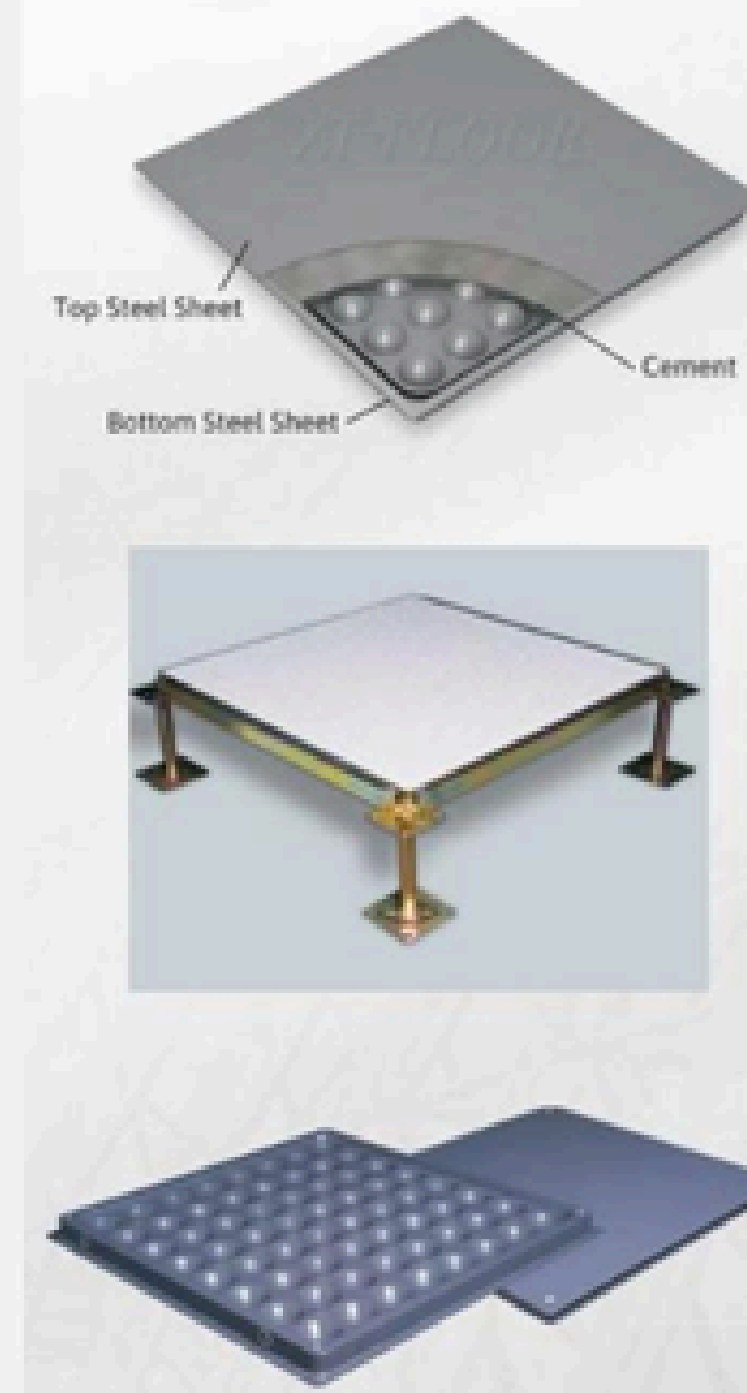
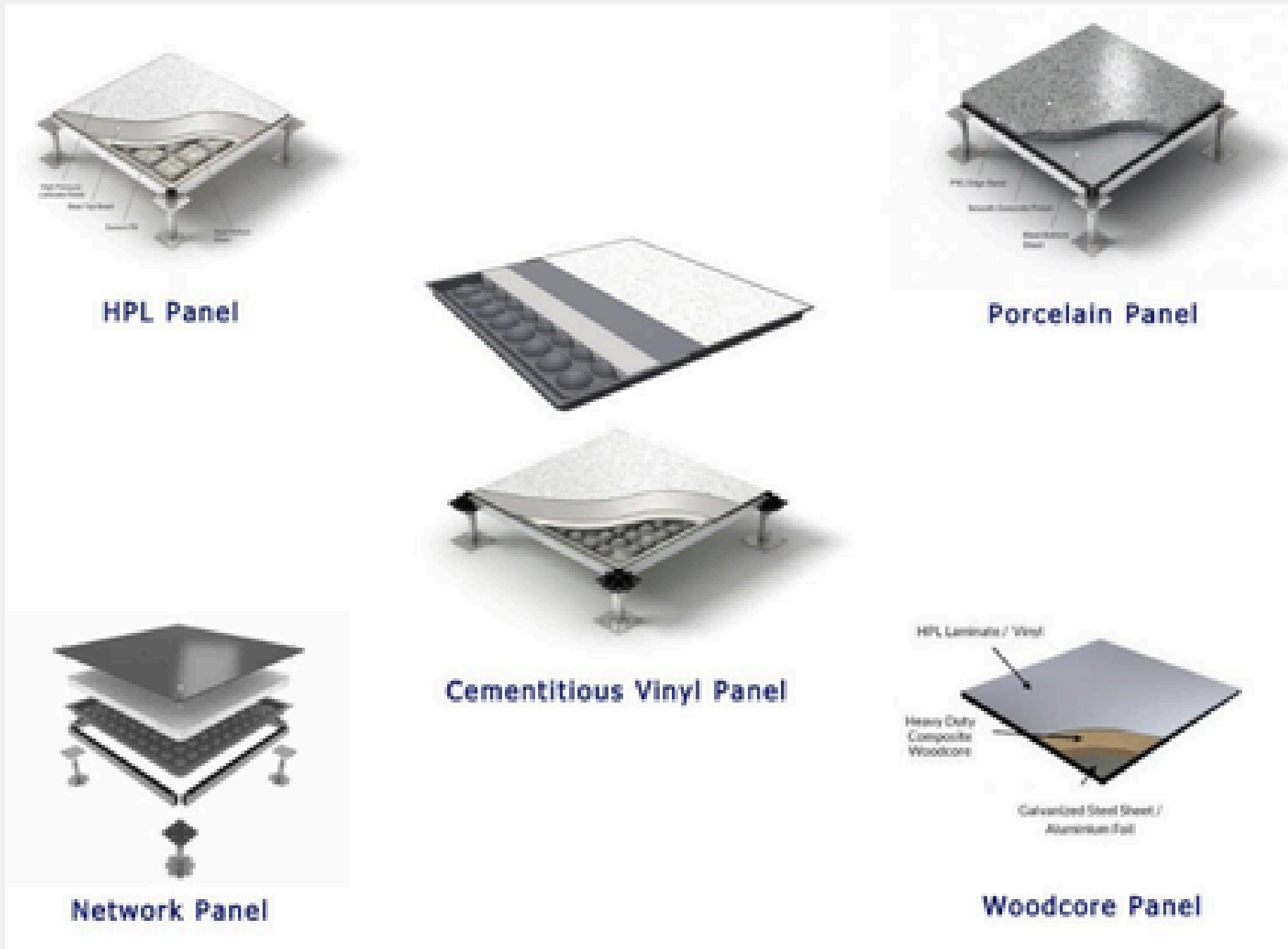

## SC 800 Grade Series

### Characteristics:

- Light Weight system
- Excellent Concentrated Load/Point Load, UDL and Rolling Load
- Non-combustible material
- Good Resistance against Moisture/Humidity
- Good Acoustical Properties
- Fully Interchangeable
- Available in Various sizes
- Available in various finishes

### Area of Application :

- General Office
- Server Room
- Data Centre
- Mobile Switch Room
- Control Room
- Library
- Casino

### Available Top finish :

- Carpet
- Antistatic Laminate/HPL
- Conductive Vinyl
- Ceramic or Marble
- Timber/Wood
- Linoleum

### Performance Data :

Size	600mm x 600mm / 610mm x 610mm 600mm x 800mm
Thickness	33.5 – 36mm (Depending on Top Finish)
Concentrated Load	3.56 Kn or 363 Kg. Over 25mm Square
UDL	19.79 Kn/Sq.Mtr. or 2018 Kg./Sq.Mtr.
Impact Load	670 N or 68 Kg.
Fire Rating	Class 'D' As per BS 476

# COMPLETED PROJECT PICTURES

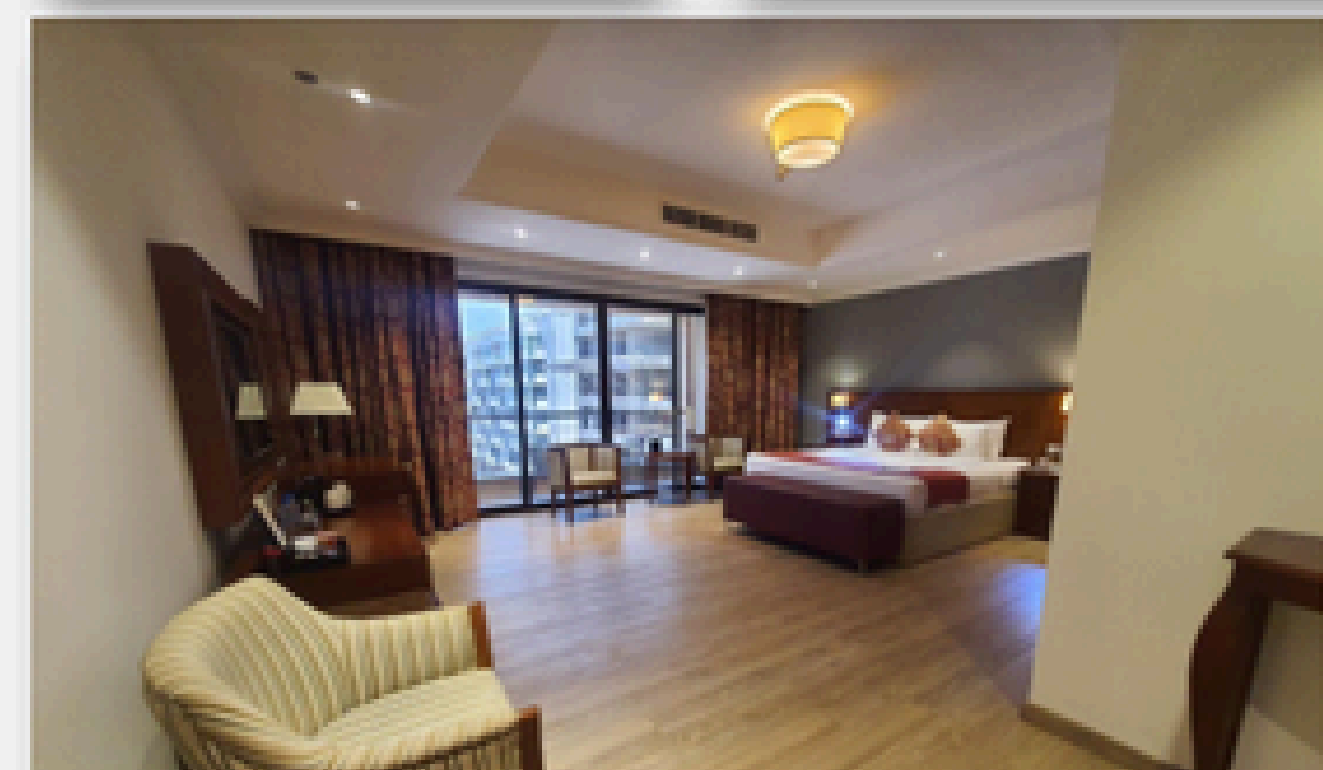
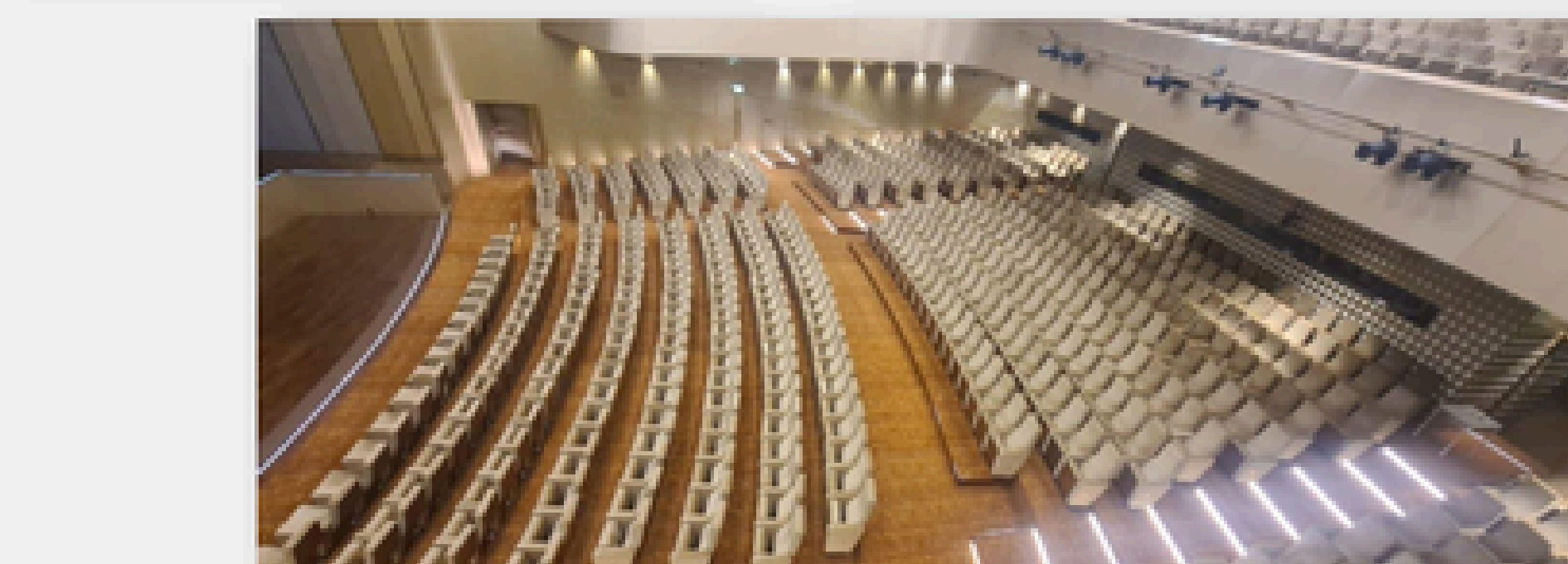
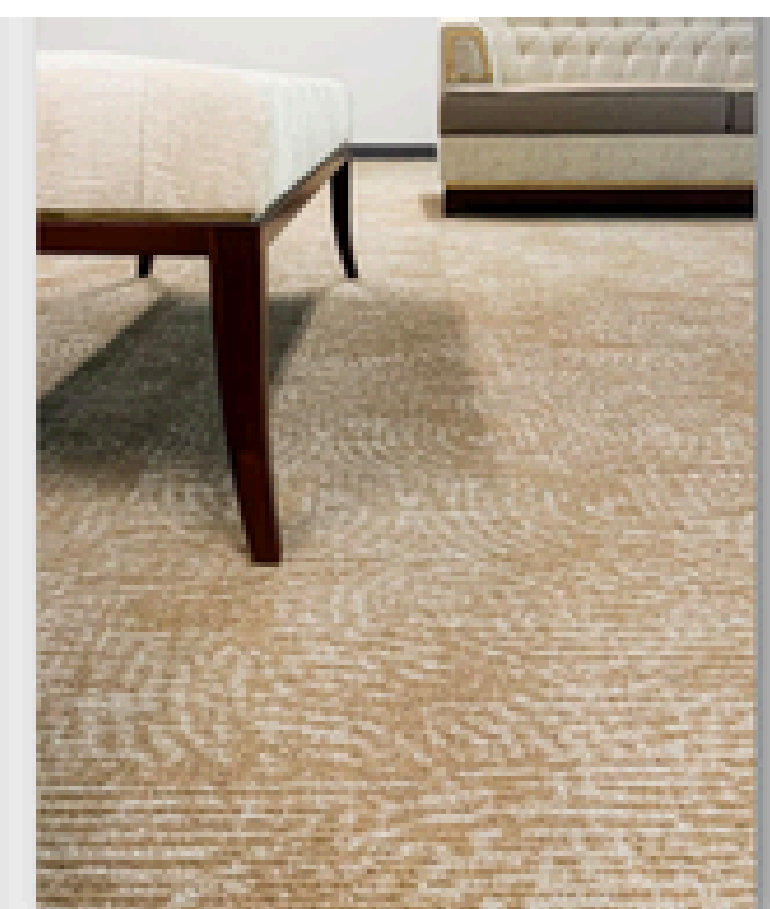
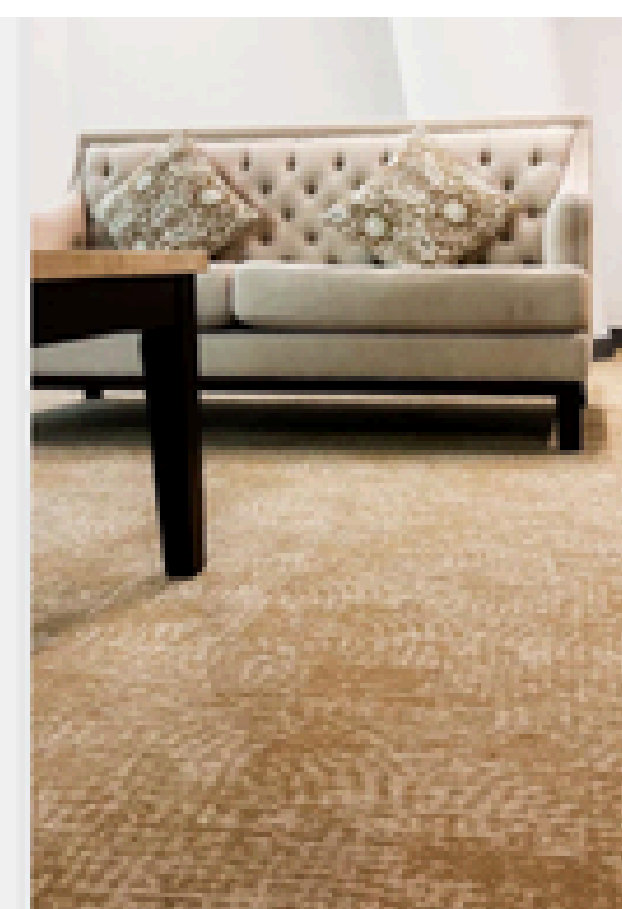
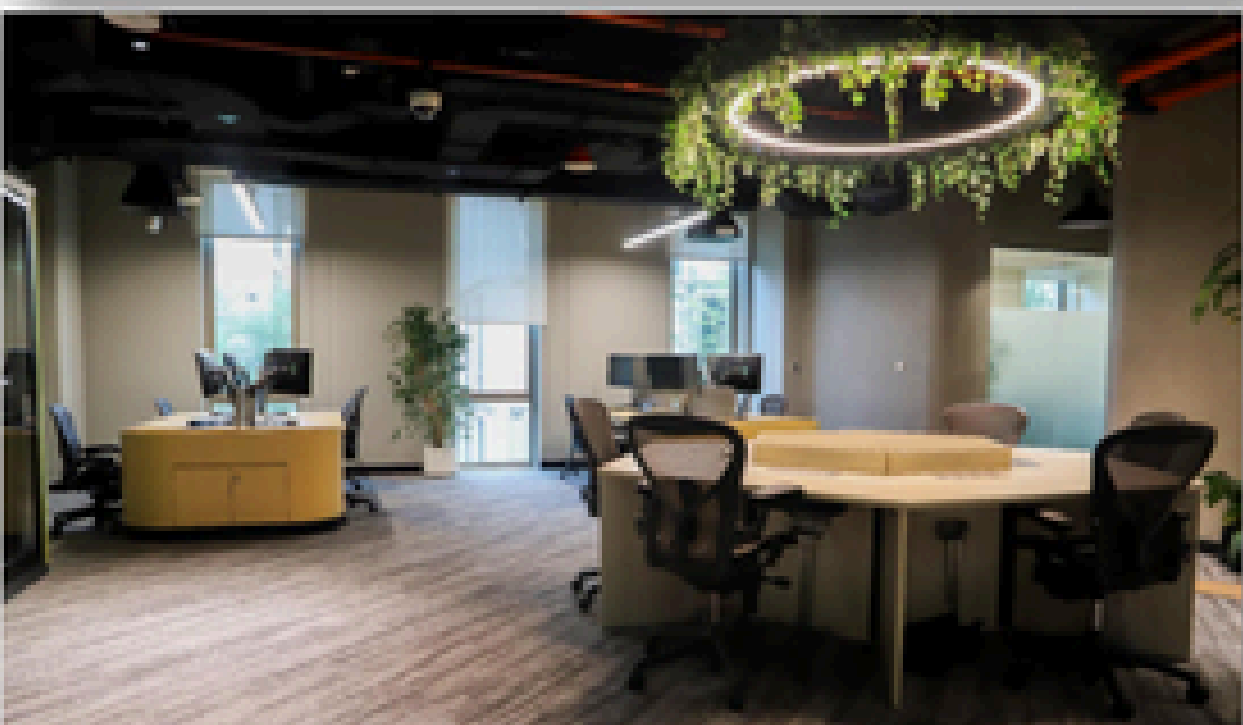





## NATURAL HARMONY

Tactile Craft perfectly complements other interior elements. The collection adds warmth and comfort to smaller meeting rooms while bringing a refined touch to large, open-plan hybrid spaces.

Each design is available in an earthy palette of warm neutrals, complemented by soft blues, mossy greens, and mute yellows.

### TACTILE CRAFT 1



TACTILE CRAFT 3



# Vinyl Flooring

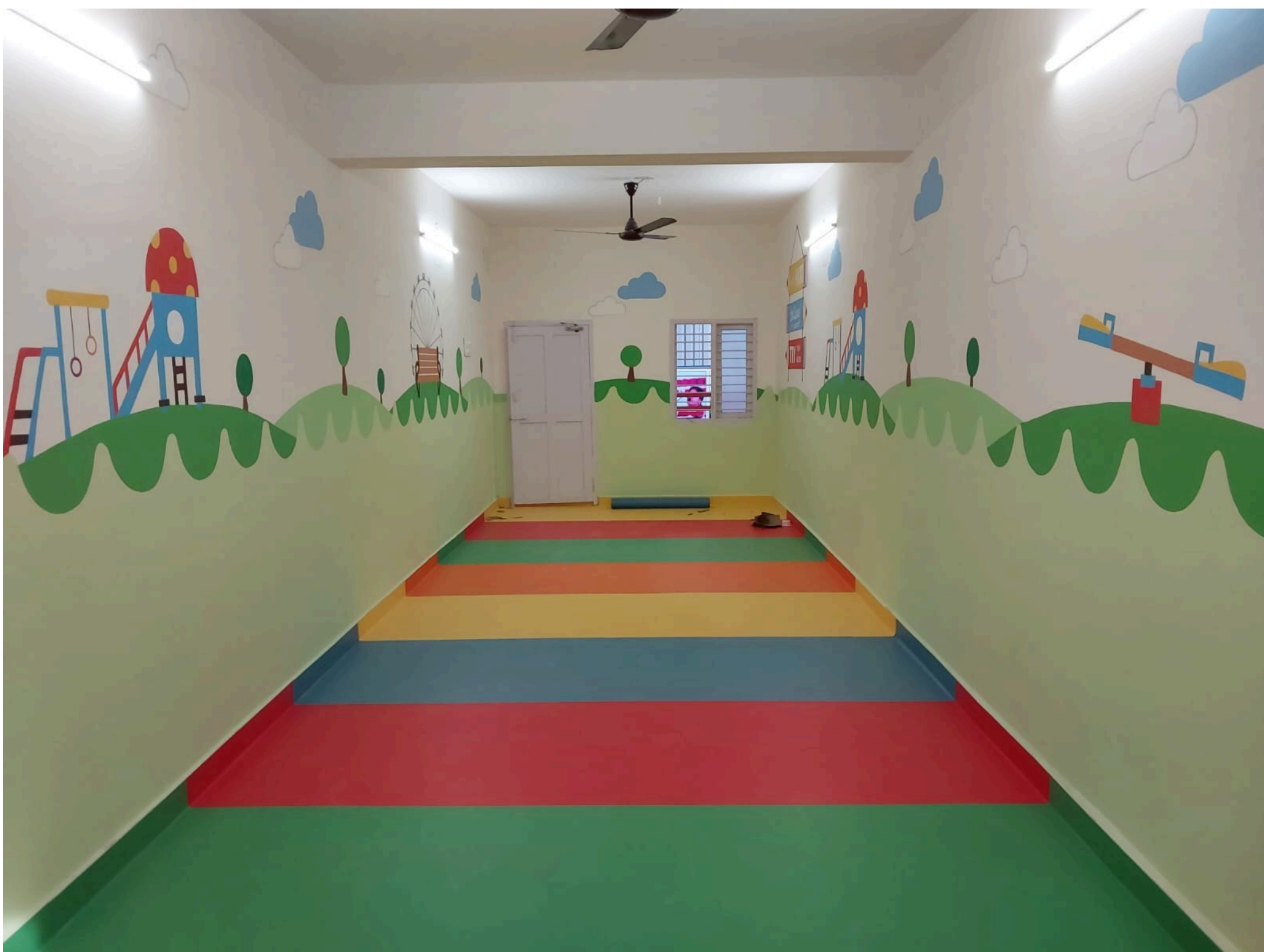

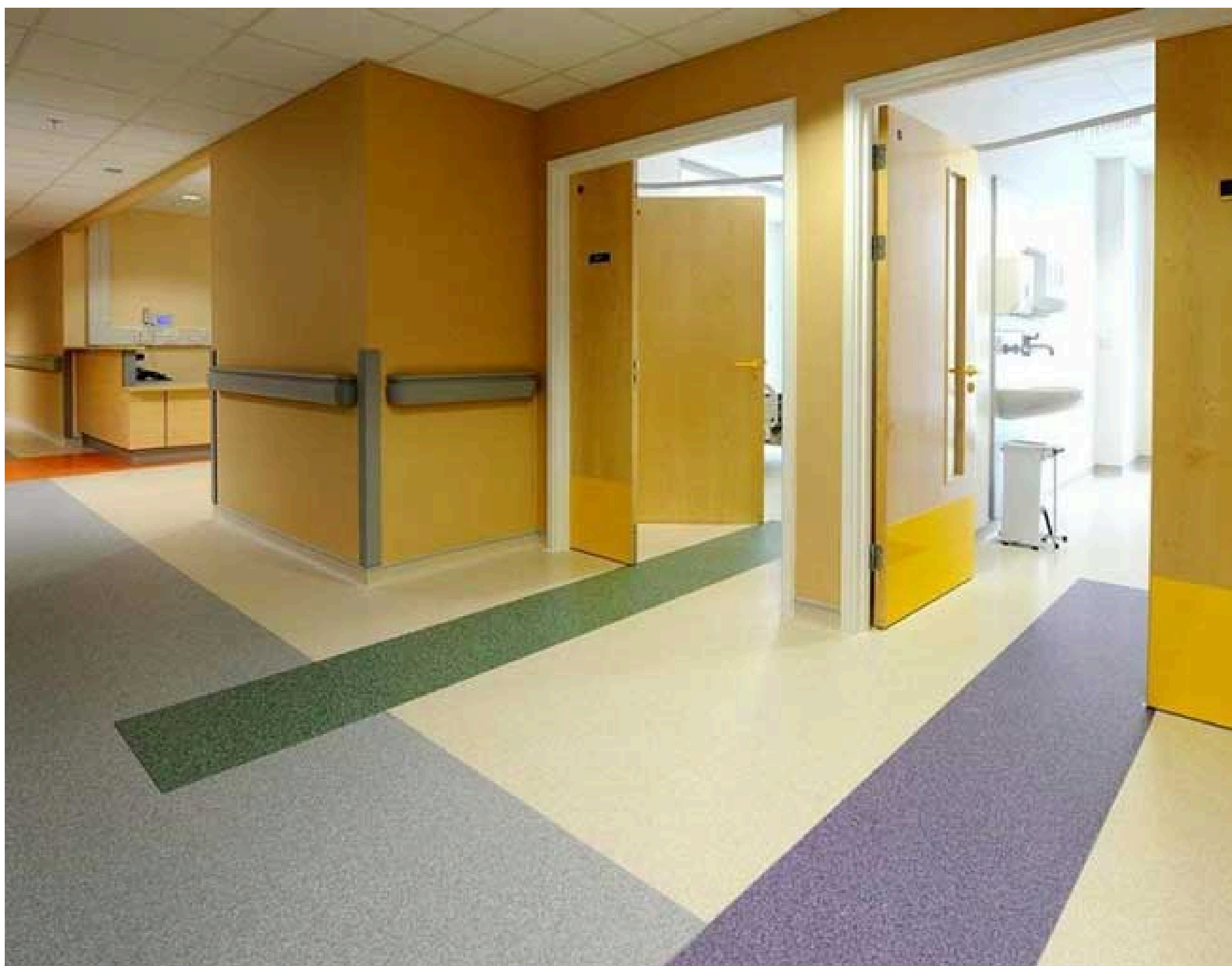



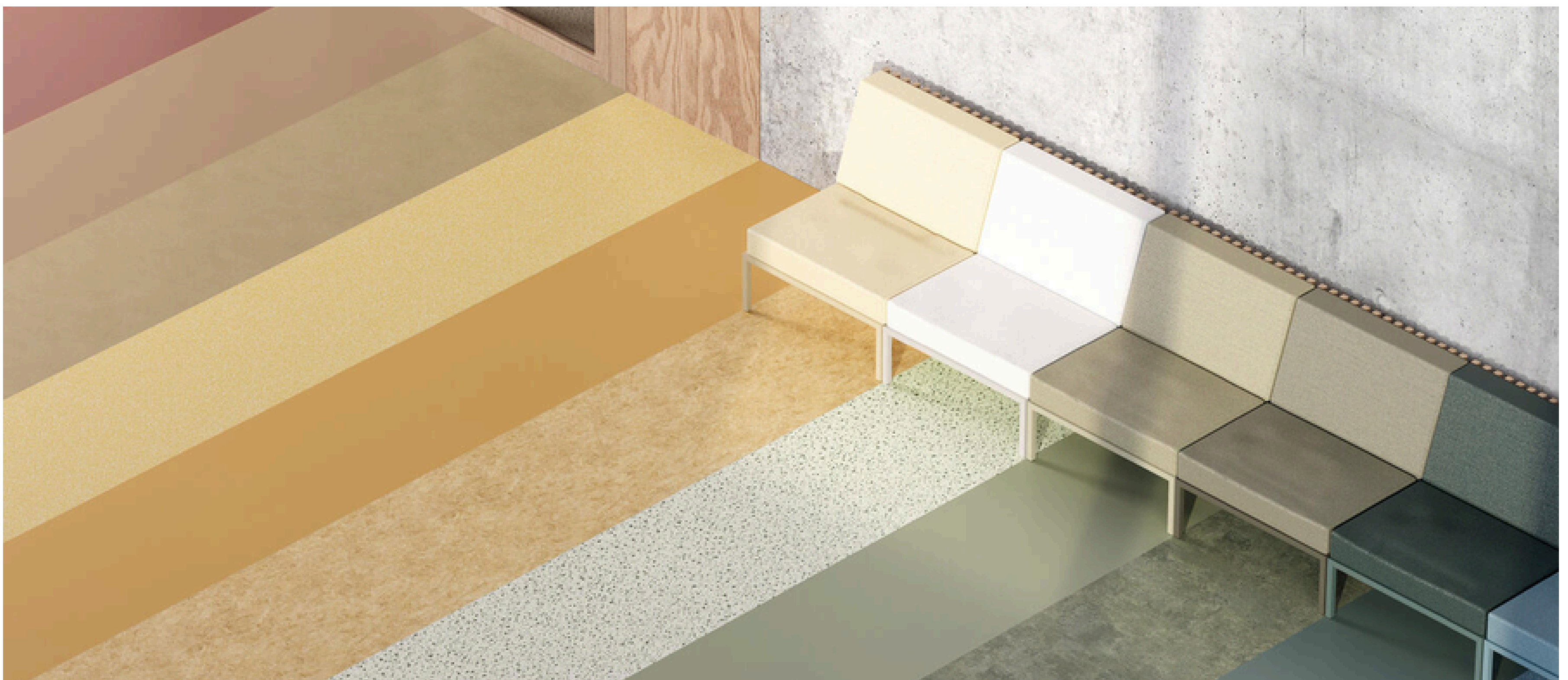





# Raised Access Flooring

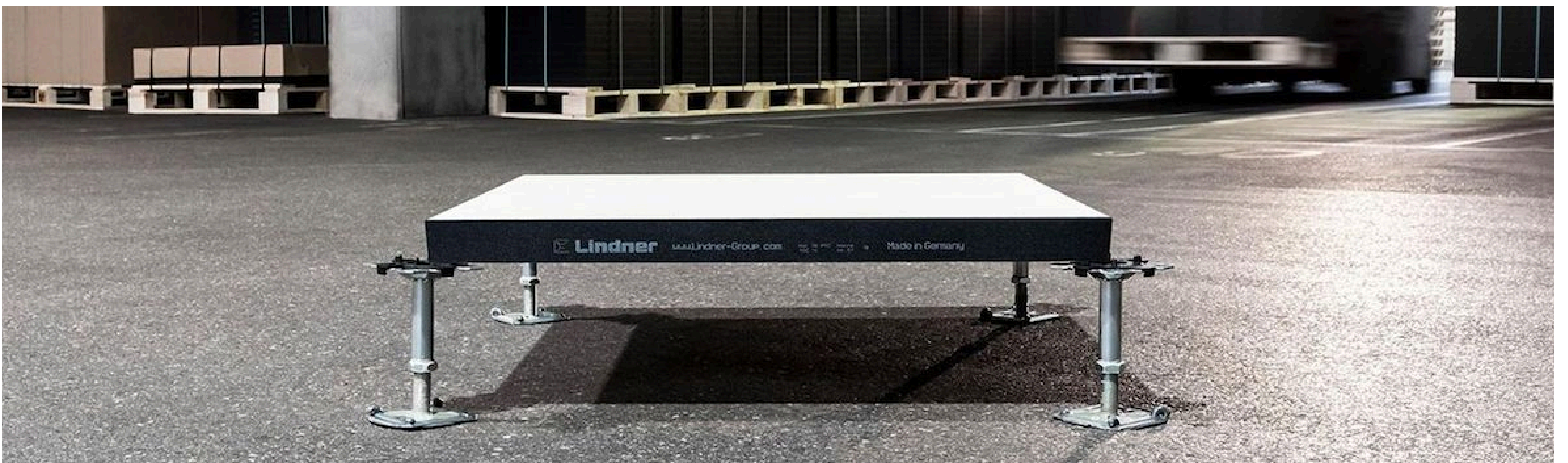
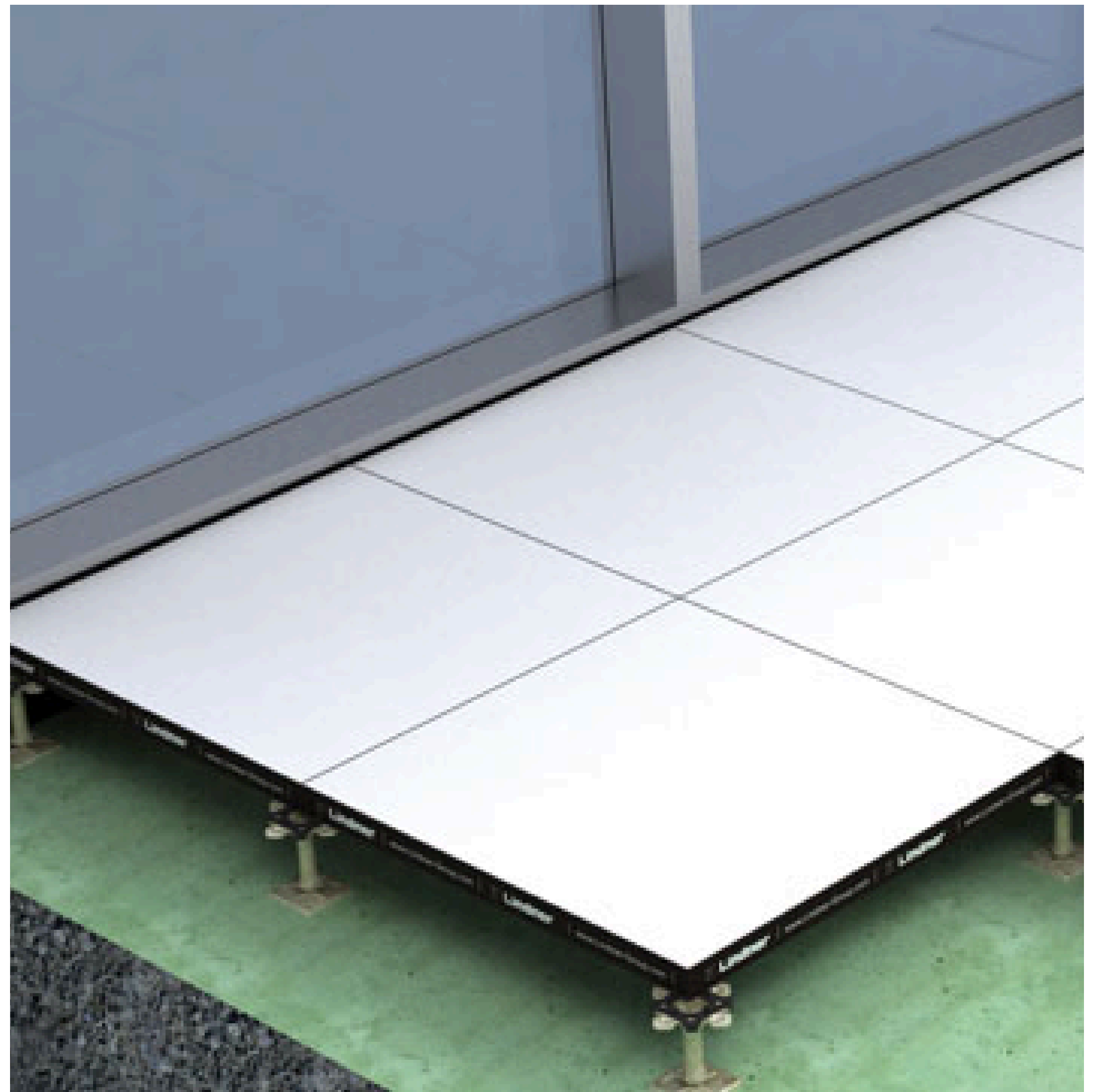
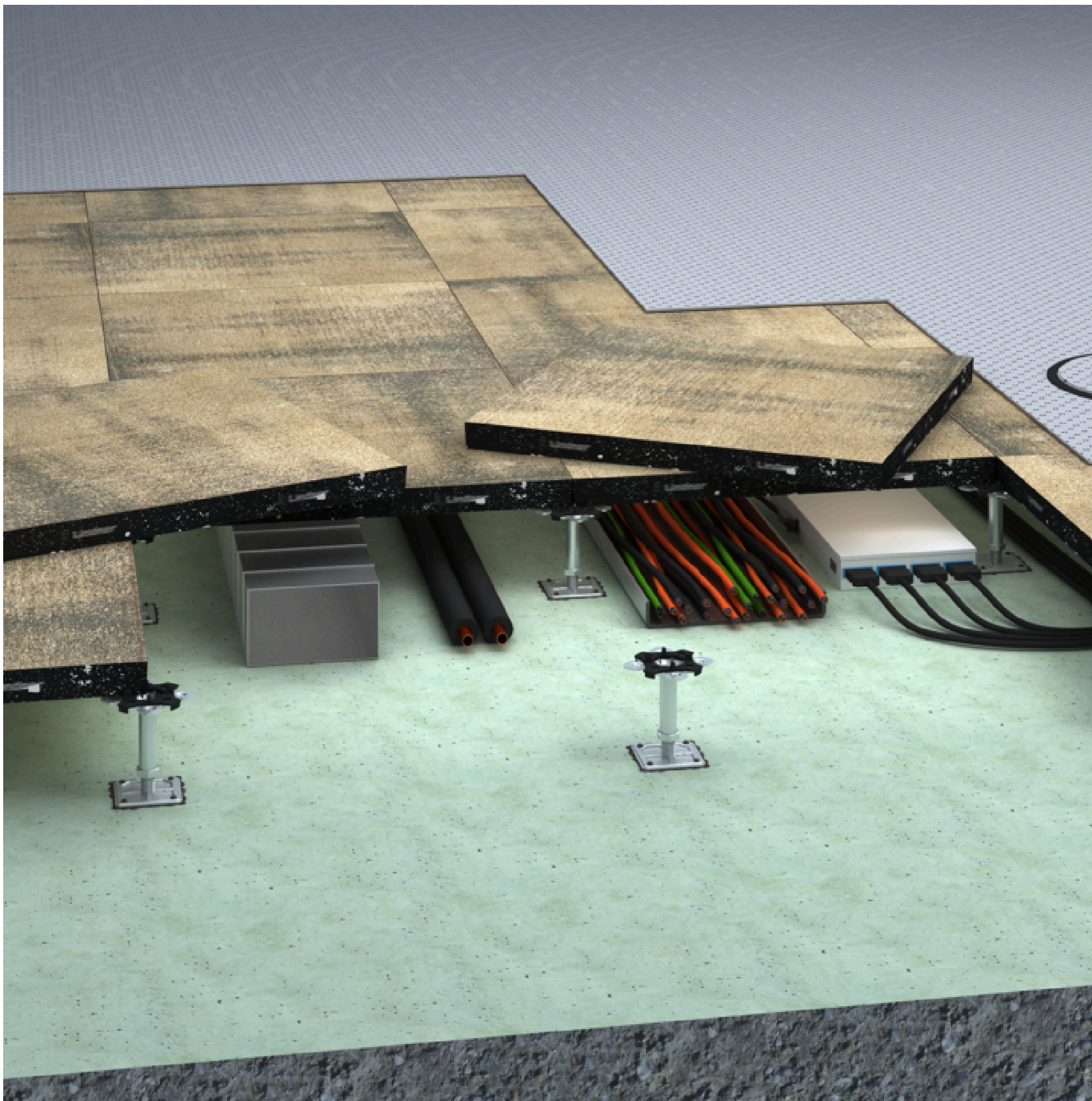
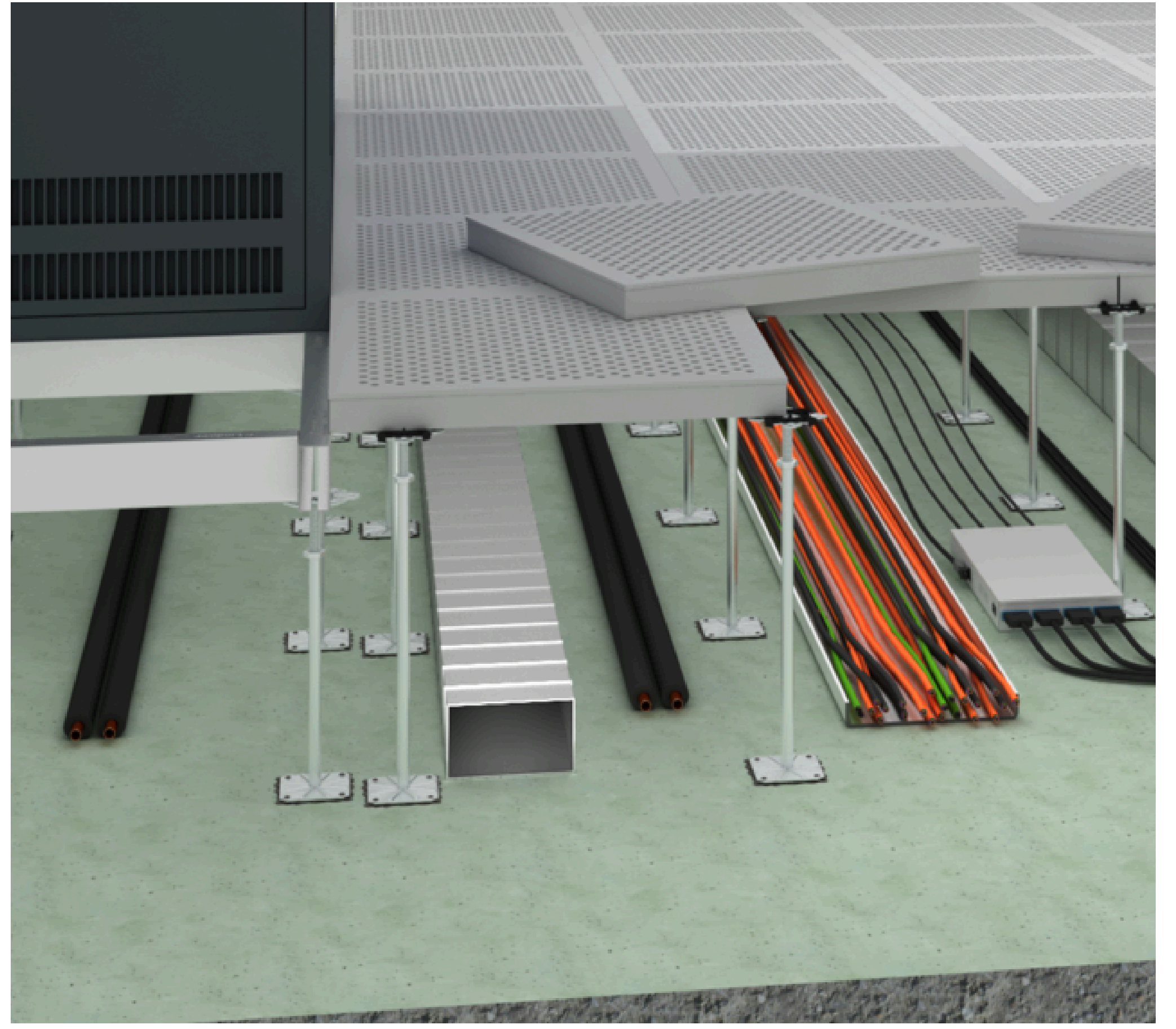
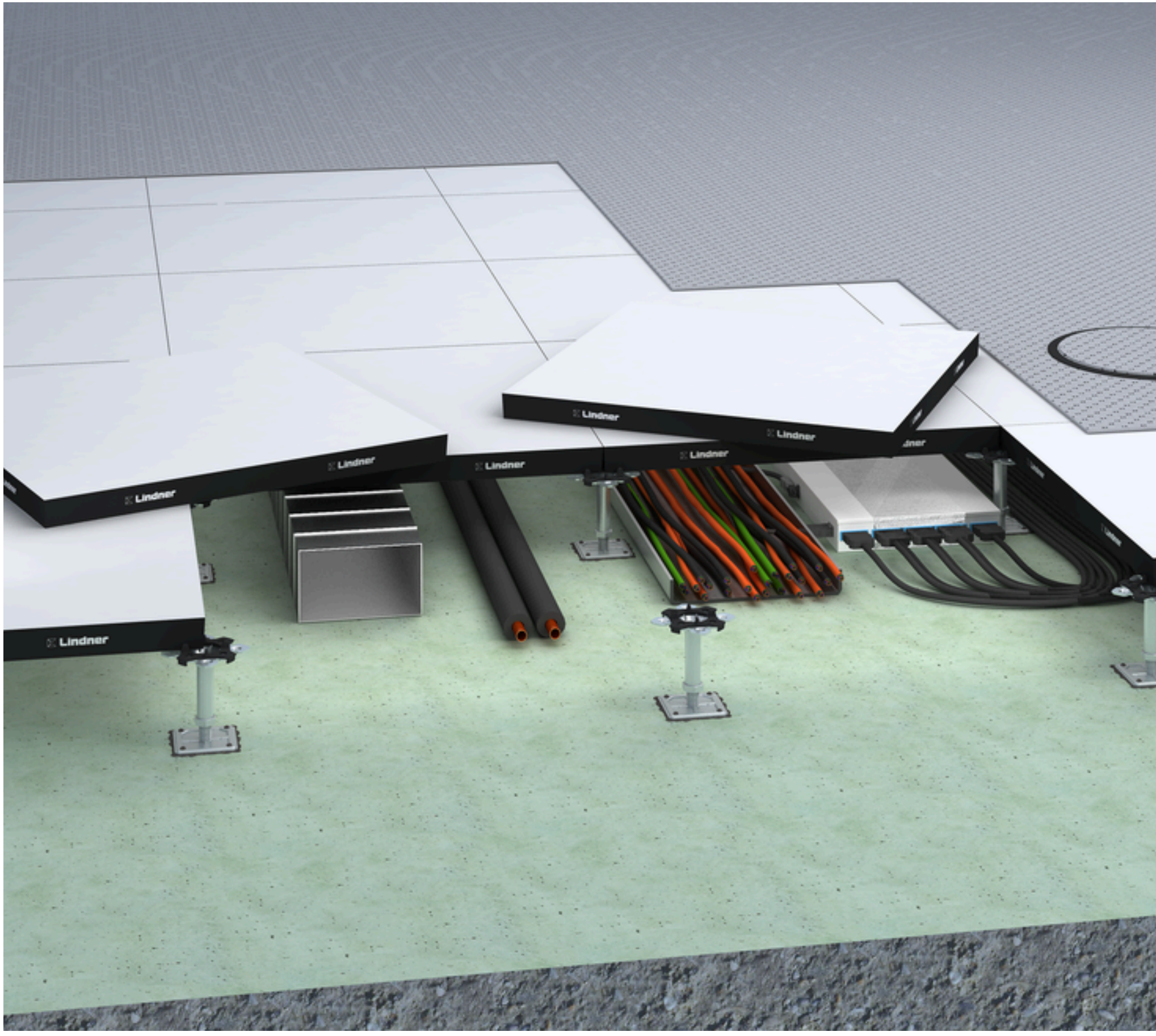

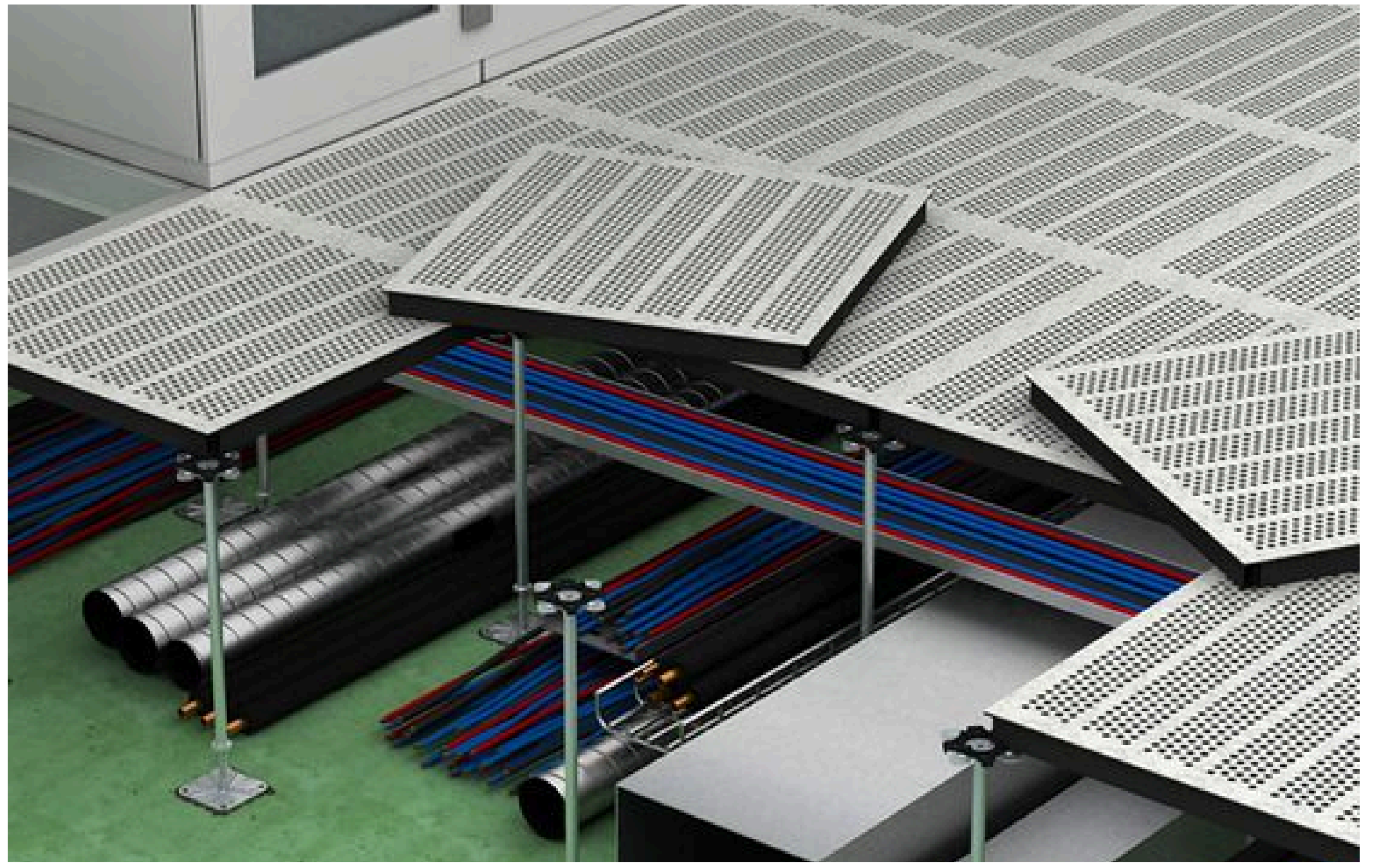
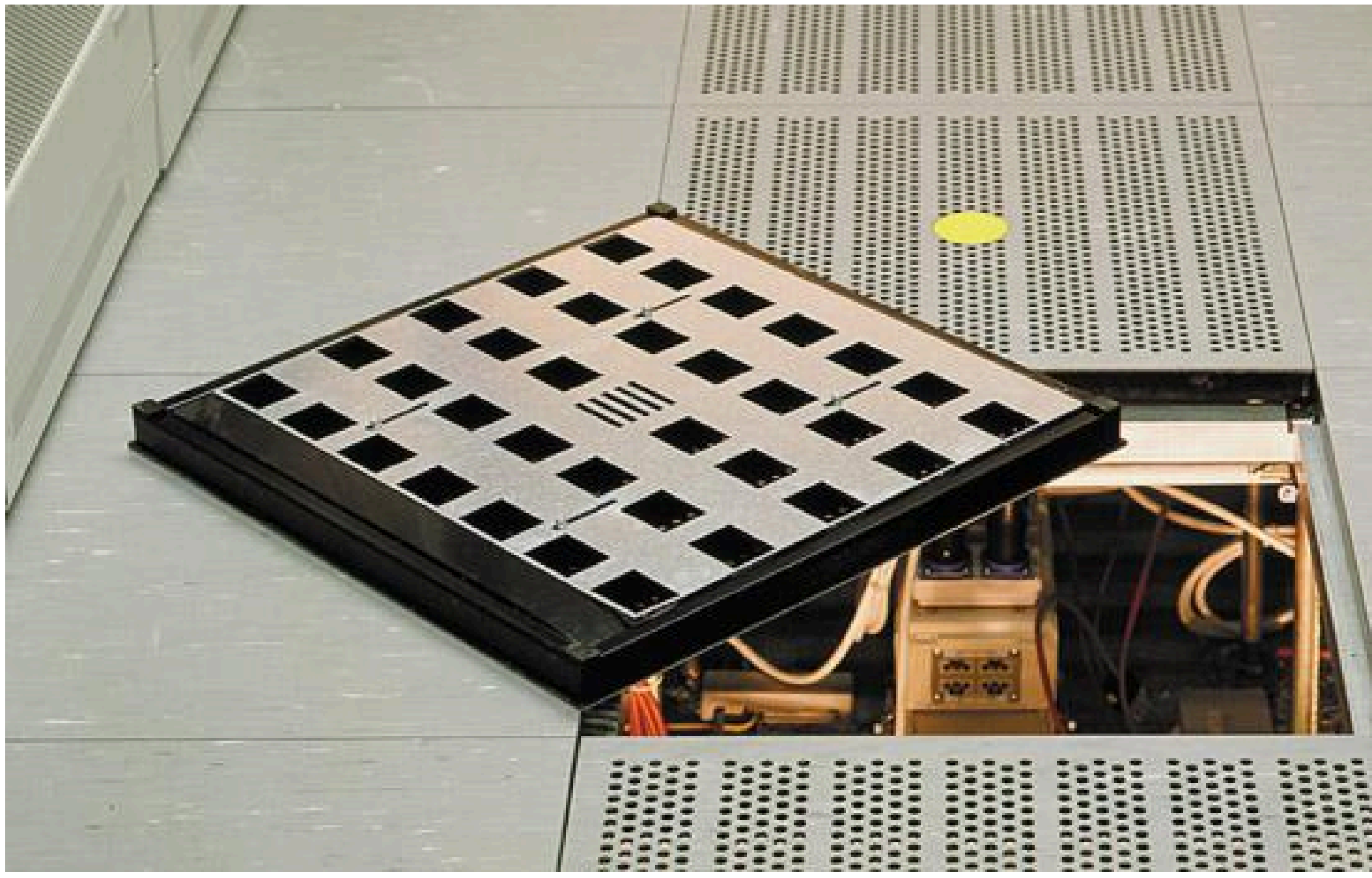

# CERTIFICATIONS

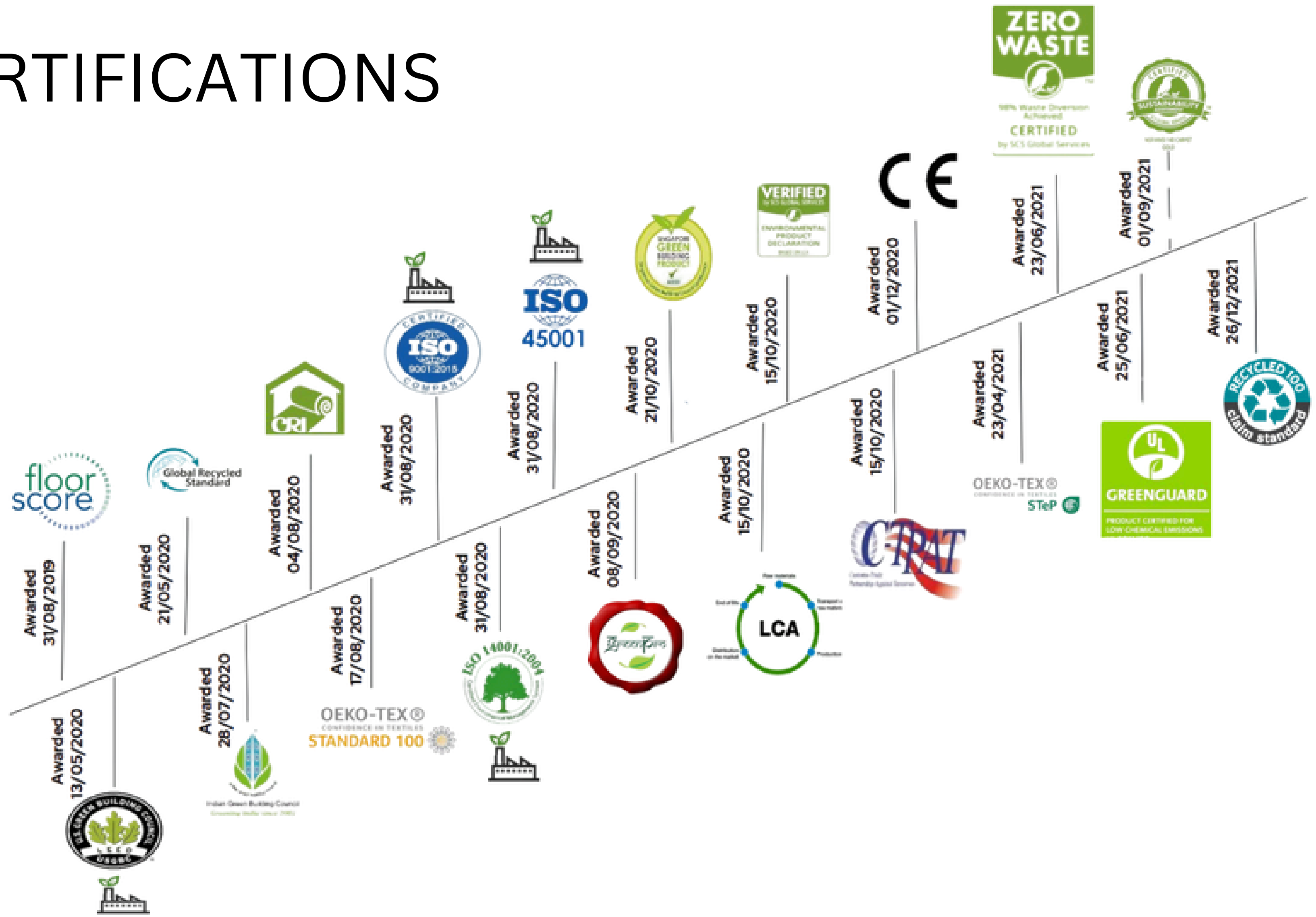

# OUR VALUED CUSTOMERS





UNITED ARAB EMIRATES  
MINISTRY OF CABINET AFFAIRS

UNITED ARAB EMIRATES  
MINISTRY OF CABINET AFFAIRS  
PRIME MINISTER'S OFFICE



الإمارات العربية المتحدة  
وزارة شؤون مجلس الوزراء  
مكتب رئاسة مجلس الوزراء

UNITED ARAB EMIRATES  
MINISTRY OF PRESIDENTIAL AFFAIRS



الإمارات العربية المتحدة  
وزارة شؤون الرئاسة

مجلس الإمارات للإعلام  
UAE MEDIA COUNCIL



UNITED ARAB EMIRATES  
MINISTER OF STATE FOR ARTIFICIAL INTELLIGENCE,  
DIGITAL ECONOMY & REMOTE WORK APPLICATIONS OFFICE

بلدية دبي  
Dubai Municipality



DP WORLD

مجمع الشارقة للبحوث  
والتكنولوجيا والابتكار  
Sharjah Research Technology  
and Innovation Park



هيئة الموارد العامة  
GENERAL RESSOURCES AUTHORITY

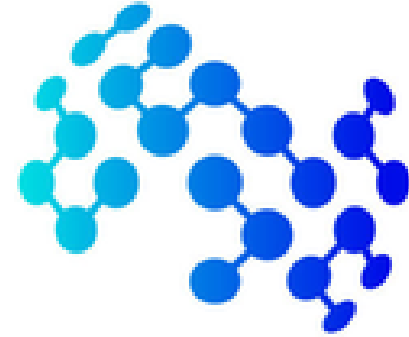

MOHAMED BIN ZAYED  
UNIVERSITY OF  
ARTIFICIAL INTELLIGENCE



جمارك دبي  
Dubai Customs

avyanco®  
Global Startup Advisory



مؤسسة الموانئ والجمارك والمنطقة الحرة  
Ports, Customs and Free Zone Corporation



برجيل  
burjeel  
Hospital

ADAM  
VITAL  
HOSPITAL



KEO

كيوانترناشيونال كونسلتنس  
KEO International Consultants

3 BOND  
INTERIORS

MAS

FLOOR  
MASTERS  
WHERE GOODNESS RISES

RECTANGLE  
INTERIORS - 1999

P&D  
PILATES & DANCE

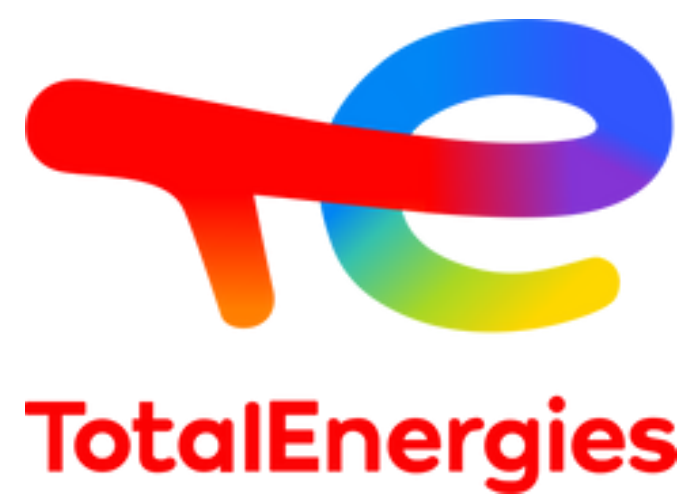

## Project Reference

King Khaled University Hospital	2020	KSA	Healthcare
Kuwaiti Hospital	2020	UAE	Healthcare
Labib Medical Center	2020	Lebanon	Healthcare
King Faisal Specialist Hospital & Research Center - Madina	2020	KSA	Healthcare
Rochester Institute	2020	UAE	Healthcare
Sidra Medical Center	2020	Qatar	Healthcare
Sohar Hospital	2020	Oman	Healthcare
Al Bahya School	2020	UAE	Education
Al Falah School	2020	UAE	Education
Al Ghad Medical College	2020	KSA	Education
Al Riydah School	2020	UAE	Education
Abu Dhabi Islamic Bank	2020	UAE	Workplace
Bank Muscat Outlets	2020	Oman	Workplace
DOH Headquarters	2020	UAE	Workplace
Dukhan Development	2020	Qatar	Workplace
Dur El Kuttab School	2020	KSA	Workplace
Emirate Islamic Bank	2020	UAE	Workplace
ESCWA Building	2020	Lebanon	Workplace

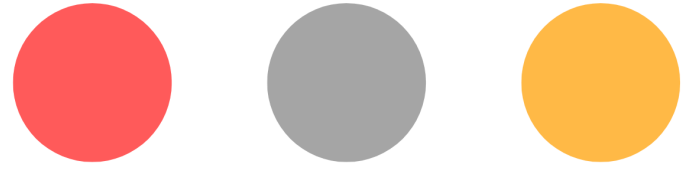

FUTURE

WORKPLACE

Your Furniture & Flooring Partner

LET'S  
CONNECT

### Head Office

#### Dubai

101, SKB Plaza, Sheikh Zayed Road, Dubai

PO Box: 452449

Ph: +971 4 263 3521

✉ info@fwp.ae

🌐 www.fwp.ae

#### Abu Dhabi

546, Hanging Garden Tower, Hamdan Bin  
Mohammed St - Al Danah, Abu Dhabi

Ph: +971 2 667 3738

✉ info@fwp.ae

🌐 www.fwp.ae

#### Riyadh

King Abdullah Financial District  
Riyadh, Kingdom of Saudi Arabia

Ph: +971 52 600 5255

✉ info@fwp.ae

🌐 www.fwp.ae